

**DECLARATION OF COVENANTS,
CONDITIONS, RESTRICTIONS, AND EASEMENTS
FOR
CONESTOGA PUD AND
CONESTOGA METROPOLITAN DISTRICT NOS. 1-5**

Declarant: Conestoga Developers Company, LLC, a Colorado limited liability company

Metropolitan

District: Conestoga Metropolitan District Nos. 1-5

**Conestoga Metropolitan District Nos. 1-5
c/o 1035 37th Ave. Court
Greeley, CO 80634**

TABLE OF CONTENTS

<u>Description</u>	<u>Page</u>
RECITALS	1
ARTICLE I DEFINITIONS.....	5
Section 1.1 Definitions.....	5
Section 1.2 Other Terms in Covenants	9
ARTICLE II DESIGN AND/OR ARCHITECTURAL REVIEW.....	9
Section 2.1 Appointment of Members to ARC.....	9
Section 2.2 Term.....	9
Section 2.3 Design Review Requirements.....	9
Section 2.4 Guidelines	10
Section 2.5 Procedures.....	10
Section 2.6 Voting and Appeals.....	10
Section 2.7 Prosecution of Work After Approval.....	11
Section 2.8 Notice of Completion.....	11
Section 2.9 Inspection of Work	11
Section 2.10 Notice of Noncompliance	11
Section 2.11 Correction of None compliance.....	11
Section 2.12 Cooperation and Delegation	12
Section 2.13 Access Easement.....	12
Section 2.14 No Liability.....	12
Section 2.15 Variance	13
ARTICLE III RESTRICTIONS	13
Section 3.1 Restrictions Imposed.....	13
Section 3.2 Residential Use; Professional or Home Occupation.....	13
Section 3.3 Household Pets.....	14
Section 3.4 Temporary Structures; Unsanitary Conditions.....	14
Section 3.5 Miscellaneous Requirements and Improvements	15
Section 3.6 Vehicular Parking, Storage and Repairs	16
Section 3.7 Nuisances	18
Section 3.8 No Hazardous Activities; No Hazardous Materials or Chemicals.....	18
Section 3.9 No Annoying Light, Sounds or Odors	18
Section 3.10 Restrictions on Trash and Materials	18
Section 3.11 Lots to be Maintained	18
Section 3.12 Leases.....	19
Section 3.13 Completion of Landscaping	19
Section 3.14 Maintenance of and Non-Interference with Grade and Drainage; Irrigation Recommendations Around Foundations and Slabs	19
ARTICLE IV RESERVATION OF DEVELOPMENT RIGHTS.....	20
Section 4.1 Declarant and Builder Exemption.....	20

Section 4.2	General Provisions	20
Section 4.3	Supplemental Provisions Regarding Development Rights	22
Section 4.4	Utility Easements	23
Section 4.5	Drainage Easements	23
Section 4.6	General Provision	23
Section 4.7	Reservation for Construction	23
Section 4.8	Rights Incidental to the Construction Easement	24
Section 4.9	Maintenance Easement	24
Section 4.10	Operations and Maintenance Services and Costs	24
Section 4.11	Recorded Easements	24
Section 4.12	Emergency Easement	25
Section 4.13	Easements Deemed Appurtenant	25
Section 4.14	Order of Exercise of Development Rights	25
Section 4.15	Rights Transferable	25
ARTICLE V RELEASE, WAIVER AND CERTAIN DISCLOSURES		25
Section 5.1	Minor Violations of Setback Restrictions	25
Section 5.2	Limitation on Liability	25
Section 5.3	No Representations, Guaranties or Warranties	26
Section 5.4	Disclaimer Regarding Safety	26
Section 5.5	Development Within and Surrounding the Property	26
Section 5.6	Waiver	26
Section 5.7	Colorado Governmental Immunity Act	27
ARTICLE VI GENERAL PROVISIONS		27
Section 6.1	Rules and Regulations	27
Section 6.2	Enforcement	27
Section 6.3	Duration, Amendment and Supplement	28
Section 6.4	Severability	29
Section 6.5	Notices	29
Section 6.6	Headings	29
Section 6.7	Gender	29
Section 6.8	Runs with the Land; Binding Upon Successors	29

OWNER'S CONSENT
LENDER'S CONSENT
METROPOLITAN DISTRICTS' CONSENT
Exhibit A: Legal Description of Property

**DECLARATION
OF COVENANTS, CONDITIONS, RESTRICTIONS AND EASEMENTS
FOR THE CONESTOGA PUD**

THIS DECLARATION OF COVENANTS, CONDITIONS, RESTRICTIONS AND EASEMENTS FOR THE CONESTOGA PUD (the "Declaration") are made and entered into to be effective as of the 8th day of December, 2017 by Conestoga Developers Company, LLC, a Colorado limited liability company, its heirs, affiliates, successors and assigns (collectively referred to hereinafter as "Declarant"), upon the following terms and conditions:

RECITALS

WHEREAS, Declarant is the owner of that certain real property located in Weld County, Colorado, within the Town of Ault, as more particularly described in **Exhibit A**, attached hereto and incorporated herein by this reference, as supplemented and amended from time to time, (the "Property"); and

WHEREAS, Declarant desires to create a system of covenants, conditions, restrictions, easements, reservations, rights-of-way, obligations, liabilities and other charges to protect and enhance the quality, value, aesthetics, desirability, and attractiveness of the Property and Improvements to be developed thereon, which shall be known as The Conestoga PUD (the "Development");

WHEREAS, the covenants, conditions, restrictions, easements, reservations, rights-of-way, obligations, liabilities, and other charges set forth herein are in addition to the laws of any and all applicable governmental entities with jurisdiction over the Property, including but not limited to the Town of Ault and Weld County, Colorado; and

WHEREAS, Declarant desires that all Property shall be improved, held, used, occupied, leased, sold, and/or conveyed subject to this Declaration; and

WHEREAS, the Conestoga Metropolitan District No. 1 (the "Metropolitan District," as hereinafter more fully defined) was organized under the laws of the State of Colorado pursuant to the Service Plan for Conestoga Metropolitan Districts Nos. 1, 2, 3, 4 and 5, (the "Districts") proposed to be approved by the Board of Trustees of the Town of Ault August of 2017 by Resolution 2017-__R (the "Service Plan"), which Metropolitan District shall, pursuant to Section 32-1-1004 (8) of the Colorado Revised Statutes, enforce the covenants, conditions, restrictions, easements, and provide design review services as set forth herein, for that certain real estate and Improvements in the County of Weld, State of Colorado, which is described on **Exhibit A**, attached hereto and incorporated herein by this reference (the "Property"); and

WHEREAS, the representatives of the Districts submitted to the Town Board of Trustees a Service Plan for the Districts which granted authority to the Districts to construct some or all of the public improvements, which may be provided in accordance with an Approved Development Plan or other agreement with the Town; and

WHEREAS, this Declaration shall run with the land and be binding on and inure to the benefit of all parties having any right, title, or interest in any portion of the Properties, their heirs, successors, successors-in-kind, and assigns; and

WHEREAS, Declarant further hereby states that the Metropolitan District shall maintain, care for and manage the Metropolitan District owned portions of the Property and related Metropolitan District Improvements from time to time, and perform certain functions for the benefit of the Owners as further described herein and within the Service Plan. This Declaration shall also define certain duties, powers, and rights of the Owners, Declarant, and Metropolitan District; and

WHEREAS, this Declaration does not create a Common Interest Community, as defined by the Colorado Common Interest Ownership Act at C.R.S. §38-33.3-103(8), as amended; therefore, this Declaration and its Covenants shall not be governed by the Colorado Common Interest Ownership Act or any provisions thereof.

NOW, THEREFORE, in addition to the foregoing, the Declarant for itself, its successors and assigns, and for and on behalf of all existing Owners, hereby declares that the Property and any Future Parcel(s) which is annexed to this Declaration in the manner provided for herein shall, from the date it so becomes annexed, be owned, held, transferred, conveyed, sold, leased, rented, encumbered, used, occupied, maintained, altered and improved subject to the following covenants, conditions, restrictions, easements, reservations, rights-of-way, obligations, liabilities, and other provisions set forth above and herein, as the same may be amended and/or supplemented from time to time; provided that the provisions of this Declaration and its Covenants shall apply only to those portions of the Property actually used for residential purposes or designated for such use.

ARTICLE I **DEFINITIONS**

Section 1.1 **Definitions**. When used in this Declaration, unless the context clearly indicates otherwise, capitalized terms not otherwise defined in the Plat of the Property shall have the meanings provided in the following sections of this Article:

1.1.1 “Affiliate” means any and all partnerships, ventures, limited liability companies or other entities in which the Declarant owns or any of the entities comprising the Declarant owns, either directly or indirectly, a controlling interest.

1.1.2 “Agent” means a person, firm, corporation or other entity employed or engaged as an independent contractor by the Declarant or Metropolitan District.

1.1.3 “Annexed Property” means any Future Parcel(s) or portion thereof, which is annexed to this Declaration by means of a Supplemental Declaration.

1.1.4 “Architectural Review Committee” or “ARC” shall mean and refer to the committee or committees created pursuant to the terms of this Declaration established to review and approve plans for the construction or alteration of Improvements on Lots as set forth in **Article II** of this Declaration.

1.1.5 “Board of Directors” or “Board” means the Board of Directors of the Conestoga Metropolitan District No. 1, its successors and assigns.

1.1.6 “Covenants” means the covenants, conditions, restrictions and easements of Conestoga contained in this Declaration, as amended and supplemented from time to time.

1.1.7 “Declarant” “Developer” means Conestoga Developers Company, LLC, a Colorado limited liability company and/or any other Person to whom the Declarant may, at any time from time to time, assign one or more of the Declarant’s rights (which shall be the extent of the Declarant’s rights to which such assignee succeeds); provided, that no assignment of any Declarant rights shall be effective unless such assignment is duly executed by the assignor Declarant and recorded in Weld County, Colorado. The term “Declarant” as used herein includes any entity that results from reorganization or restructuring of the existing entity or the conversion thereof to another form of entity. For purposes of determining which Lots or Future Parcels are owned by Declarant, “Declarant” shall automatically be deemed to include “Affiliates” as that term is defined in this Article I.

1.1.8 “Declaration” shall mean this Declaration of Covenants, Conditions, Restrictions and Easements for The Conestoga PUD, as amended and supplemented from time to time.

1.1.9 “Dedicated Easements” shall mean the utility and/or drainage easements granted through the Property to the appropriate governmental entity, or public or private utility for providing utility service or drainage facilities to the Property.

1.1.10 “Development” shall mean The Conestoga PUD development subject to this Declaration, consisting of the Property described in **Exhibit A** attached hereto and incorporated herein by this reference, as supplemented and amended from time to time. The Development is intended to be the property within the boundaries of Conestoga Metropolitan Districts Nos. 1, 2 and 3 and all future Annexed Property.

1.1.11 “District Properties” means all real and personal property including any Improvements, common areas, facilities and related appurtenances, now or hereafter owned by the Metropolitan District, or with respect to which the Metropolitan District holds an easement for the use, care or maintenance thereof held for the common use and enjoyment of certain of the Owners, or certain Owners, as the case may be, and for other purposes as may be permitted hereunder.

1.1.12 “Future Parcels” means and refers to any real property adjacent to the Property or in its vicinity which the Declarant identifies as annexable to this Declaration or included into the Development, in any recorded document executed by it which refers to this Declaration, as hereafter provided. Declarant need not own future Parcels so long as the Owner thereof consents to the potential annexation of such real estate to this Declaration. Future Parcels may be added to this Declaration by the Declarant, provided such Future Parcels are properly annexed to the Town of Ault, included within one of the Conestoga Metropolitan Districts, and provided such inclusion is in accordance with law and any Service Plan or Town requirements.

1.1.13 “Governing Board,” means the governing board of Conestoga Metropolitan District No. 1.

1.1.14 “Guidelines” shall mean the guidelines and rules published, and as amended and supplemented from time to time in accordance with the terms therein, by the Architectural Control Committee.

1.1.15 “Improvement(s)” shall mean and include the following: (a) the construction, installation, alteration, demolition in whole or in part, or expansion of any exterior improvement, building, structure, appurtenance, or other improvements, including, but not limited to, buildings, outbuildings, swimming pools, tennis courts, patios, patio covers, awnings, solar collectors, painting or other finish materials on any visible structure, additions, walkways, sidewalks, trails, bridges, sprinkler systems, garages, driveways, parking areas, fences, including gates in fences, basketball backboards and hoops, swing-sets or other play structures, screening walls, retaining walls, stairs, decks, exterior light fixtures, poles, signs, exterior tanks, utilities, facilities, pipes, lines, solar panels, radiant gas piping and exterior air conditioning, cooling, heating and water softening equipment, if any; (b) the staking, clearing, grading, excavation, filling or similar disturbance to the surface of the land, including without limitation any change of grade, change of ground level, change of drainage pattern, or change of stream bed or course, ditch improvements, drainage, retention and detention ponds or facilities, storm sewer and other collection facilities; (c) all initial planting of and subsequent material modifications to landscaping, hedges, windbreaks, berming, plantings, trees, shrubs, flowers, vegetables, sod, gravel, bark, and all planting, clearing or removing of trees, shrubs, grass or perennial plants, but in each instance excluding removal of dead or diseased plants and trees and excluding any replacement that is substantially similar to the item being replaced; (d) any change or alteration to the exterior appearance of Improvements previously approved by the ARC, including any change in finish material, color or texture; (e) the repainting and resurfacing of exterior surfaces of structures, including roofing materials, gutters, downspouts, drain spouts, exterior siding or stucco finish, entry doors, windows, trim around doors and windows, surfaces of garage doors, external vents and flues and glass surfaces, exclusive of any replacement that is substantially identical to the item being repainted or resurfaced; and (f) reconstruction of any structures.

1.1.16 “Lot” means each platted lot that is now or hereafter included in the real estate described on the attached **Exhibit A**, as the same may be subdivided or replatted from time to time (and “Lot” shall include all lots created as a result of such subdivision or replatting), as well as any other platted lots now or hereafter included in any real estate annexed to this Declaration.

1.1.17 “Metropolitan District” or “District” means the Conestoga Metropolitan District No. 1, a quasi-municipal corporation and political subdivision of the State of Colorado, its successor or assign, and/or any other metropolitan district(s) to whom Then-Metropolitan District may, from time to time, transfer or assign any or all of the rights, duties obligations, and responsibilities delineated in this Declaration. Each such assignment or transfer, if any, shall be effective upon recording in Weld County, Colorado, of a document of transfer or assignment, duly executed by Then-Metropolitan District. In the event that Metropolitan District ceases to exist, Declarant may appoint a successor entity to serve as enforcer of this Declaration, which entity shall assume all rights and responsibilities of the Metropolitan District under this

Declaration. The terms and conditions of this Declaration shall apply to property within The Conestoga PUD and property within the boundaries of each of the Conestoga Metropolitan Districts Nos. 1-5, which boundaries may be amended from time to time.

1.1.18 "Owner" means each fee simple title holder of a Lot, including without limitation the Declarant or any other Person who owns a Lot, but does not include a Person having an interest in a Lot solely as security for an obligation.

1.1.19 "Period of Declarant Control" shall mean that period of time in which the Declarant is entitled to enforce, amend, revise and/or supplement this Declaration, promulgate rules and regulations subject to this Declaration, and appoint members of the Architectural Review Committee. The Period of Declarant Control will begin with the recording of this Declaration and shall continue to run for 20 years after the date of the recording of the final Plat of the final filing within the Property, unless terminated earlier by Declarant.

1.1.20 "Person" means a natural person, a corporation, a limited liability company, a partnership, a trust, a joint venture, an unincorporated association, or any other entity or any combination thereof and includes, without limitation, each Owner, Builder, Developer and the Declarant.

1.1.21 "Project Documents" means this Declaration, rules and regulations, Guidelines and any documents now or hereafter adopted by or for the Metropolitan District, as amended or supplemented from time to time.

1.1.22 "Property" means the real estate described on the attached **Exhibit A**, and any Future Parcel(s), or portion thereof, which has been annexed hereto by a Supplemental Declaration or otherwise as provided herein; all of which may be supplemented and amended from time to time, as the same may now or hereafter be improved, and as the Declarant may now or hereafter subdivide or re-subdivide any portion thereof; provided, however, that the Property shall include any real estate and Improvements that are annexed and shall not include any real estate or Improvements that have been withdrawn, as provided in this Declaration.

1.1.23 "Supplemental Declaration" shall mean a declaration or covenants recorded by Declarant, with respect to any Future Parcel, or portion thereof, which annexes such parcel to the terms of this Declaration. A Supplemental Declaration may establish additional covenants, conditions and restrictions applicable to such portion of real property, may contain exceptions, deletions or modifications from the covenants, conditions, restrictions and easements contained herein applicable to such portion of real property. Any recorded document that establishes or creates a declaration or covenant shall be deemed to be a Supplemental Declaration for the purposes of this Declaration, whether or not it is labeled or identified as such.

1.1.24 "Town" shall mean the Town of Ault, Colorado.

1.1.25 "Utility Easements" shall mean the reciprocal, nonexclusive easements for the purpose of providing utility easements granted pursuant to this Declaration or which may be created and identified as such in a Supplemental Declaration or other recorded document executed by Declarant and Then Owner of a Lot.

Section 1.2 Other Terms in Covenants. Other terms in this Declaration may be defined in specific provisions contained herein and shall have the meaning assigned by such definition.

ARTICLE II
DESIGN AND/OR ARCHITECTURAL REVIEW

Section 2.1 Appointment of Members to ARC. The Governing Board shall appoint the members of the Architectural Review Committee. There shall initially be three (3) members of the ARC, namely Jamie Baessler, _____, and _____. Members of the ARC may be, but need not be, directors of the Governing Board. The Governing Board may also appoint a second ARC to review Improvements that are subsequent to the Improvements originally constructed on any Lot.

Section 2.2 Term. Each member of the ARC shall serve at the pleasure of the Governing Board. In the event of the death, incapacity, or resignation of any member of the ARC, the Governing Board shall appoint a successor.

Section 2.3 Design Review Requirements.

2.3.1 No Improvements shall be constructed, erected, placed, altered, planted, applied or installed upon any Lot unless said Improvements are in full compliance with the provisions of the Project Documents and unless complete plans and specifications have been first submitted to and approved in writing by the ARC.

2.3.2 The ARC shall exercise its reasonable judgment to the end that all Improvements generally conform to and harmonize with the existing surroundings, residences, landscaping and structures. In its review of such plans, specifications and other materials and information, the ARC may require as a condition to its considering an approval request that the applicant(s) pay a review fee and/or reimburse the ARC for the expenses incurred by the ARC in the review process. A Compliance Deposit may also be required as a condition precedent to review and approval of any plans.

2.3.3 In addition to the foregoing review and approvals, the construction, erection, addition, deletion, change or installation of any Improvements shall also require the applicant to obtain the approval of all governmental entities with jurisdiction thereover, and issuance of all required permits, licenses and approvals by all such entities. Without limiting the generality of the preceding sentence, issuance of building permit(s) by the applicable governmental entity, if required, shall be a precondition to commencement of any construction of, alteration of, addition to or change in any Improvement.

2.3.4 The Governing Board of the Metropolitan District may at any time, from time to time, appoint a representative or committee of representatives to act on its behalf. If the Governing Board does so, then the actions of such representative or committee shall be the actions of the Governing Board, subject to the right of appeal as provided below. However, if such a representative or committee is appointed by the Governing Board, then the Governing Board shall have full power over such representative or committee, including without limitation the power to at any time withdraw from such representative or committee any of such authority

to act on behalf of the Governing Board and the power to at any time remove or replace such representative or committee.

2.3.5 In addition to the foregoing Sections, the ARC shall likewise have the power to delegate the responsibility for reviewing any application submitted to the ARC to a professional architect, landscape architect, engineer, or other professional Person who is qualified to review the issues raised in the application. The ARC shall also have the power to require that the applicant pay the fees reasonably incurred by the ARC in retaining such professional to review the application submitted.

Section 2.4 Guidelines. The Governing Board of the Metropolitan District is authorized to promulgate design and/or architectural standards, rules, regulations and/or guidelines (collectively the Architectural Control Handbook with Design Guidelines, hereinafter referred to as "Guidelines"). Any such Guidelines may be included in rules and regulations promulgated by the Metropolitan District as set forth in Section 6.1 of this Declaration ("Rules and Regulations"). Without limiting the generality of the foregoing, such Guidelines may contain provisions to clarify the designs and materials that may be considered in design approval, may state requirements for submissions, may state procedural requirements, or may specify acceptable Improvement(s) that may be installed without the prior approval of the ARC. By way of example, and not by way of limitation, such provisions may state that a certain style of roofing material and color is acceptable, or may state that only one or more types of fences are acceptable and no other types will be approved. The published Guidelines that may apply to a specific area may vary in another specified area, as determined by the ARC. Each area shall be identified and specified in the Guidelines established for said areas. All Improvements proposed to be constructed, and any Guidelines that are adopted, shall be done and used in accordance with this Declaration.

Section 2.5 Procedures. The ARC shall approve or disapprove all requests for approval within forty-five (45) calendar days after the complete submission of all plans, specifications, and other materials and information which the ARC may require in conjunction therewith. A stamped or printed notation, initialed by a member of the ARC, affixed to any of the plans and specifications, shall be deemed a sufficient writing. However, the ARC shall not be required to maintain records of plans, specifications or other documents or information that have been submitted to it for approval. Approval by the ARC shall be conclusive evidence of compliance with this **Article II**, provided that the Improvements are constructed in compliance with the plans and specifications as approved. Failure to approve within forty-five (45) calendar days shall be deemed disapproval.

Section 2.6 Voting and Appeals. A majority vote of the ARC is required to approve a request for architectural approval or any other matter to be acted on by the ARC, unless the ARC has appointed a representative to act for it, in which case the decision of such representative shall control. In the event a representative acting on behalf of the ARC decides a request for architectural approval which is adverse to the applicant, then the applicant shall have the right to an appeal of such decision to the full ARC, upon a written request therefor submitted to the ARC within ten (10) calendar days after such decision by the ARC's representative. In the event the ARC decides a request for architectural approval that is adverse to the applicant, then the applicant shall have the right to an appeal of such decision to the full Governing Board, upon a

written request therefor submitted to the Governing Board within ten (10) calendar days after such decision by the ARC. Notwithstanding anything to the contrary in this Declaration, the Governing Board may intercede of its own volition in matters of architectural approval by the ARC, and the Governing Board may reverse, alter, amend, adjust, change, or otherwise modify any decisions of the ARC at any time, so long as any one or more Owners are not unduly prejudiced thereby.

Section 2.7 Prosecution of Work After Approval. After approval of any proposed Improvement, the proposed Improvement shall be accomplished as promptly and diligently as possible and in complete conformity with all conditions and requirements of the approval. Failure to complete the proposed Improvement within one (1) year after the date of approval of the application or to complete the Improvement in complete conformance with the conditions and requirements of the approval shall constitute noncompliance and the Compliance Deposit shall become non-refundable; provided, however, the ARC, in its sole discretion, may grant extensions of time for completion of any proposed Improvements and proportional amounts of Compliance Deposit redemption.

Section 2.8 Notice of Completion. Upon the completion of any Improvement, the applicant for approval of the same shall give a written "Notice of Completion" to the ARC. Until the date of receipt of such Notice of Completion, the ARC shall not be deemed to have notice of completion of any Improvement on which approval has been sought and granted as provided in this Article.

Section 2.9 Inspection of Work. The ARC or its duly authorized representative shall have the right to inspect any Improvement prior to or after completion in order to determine whether the proposed Improvement is being completed or has been completed in compliance with the approval granted pursuant to this Article; provided, however, that the right of inspection shall terminate sixty (60) calendar days after the ARC shall have received a Notice of Completion from the applicant.

Section 2.10 Notice of Noncompliance. If, as a result of inspections or otherwise, the ARC finds that any Improvement has been done without obtaining the approval of the ARC, or was not done in substantial compliance with the approval that was granted, or was not completed within one (1) year after the date of approval, subject to any extensions of time granted pursuant to Section 2.7 hereof, the ARC shall notify the applicant in writing of the noncompliance; which notice of noncompliance shall be given, in any event, within sixty (60) calendar days after the ARC receives a Notice of Completion from the applicant. The notice of noncompliance shall specify the particulars of the noncompliance.

Section 2.11 Correction of Noncompliance. If the ARC determines that a noncompliance exists, the Person responsible for such noncompliance shall remedy or remove the same (and return the subject real estate and/or Improvements or structure to its original condition) within a period of not more than forty-five (45) calendar days from the date of receipt of the notice of noncompliance. If such Person does not comply with the ruling within such period, the ARC may, at its option, retain the Compliance Deposit, record a notice of noncompliance against the Lot on which the noncompliance exists, may remove the non-complying Improvement or may otherwise remedy the noncompliance, and the Person

responsible for such noncompliance shall reimburse the ARC, upon demand, for all costs and expenses incurred with respect thereto in excess of the retained Compliance Deposit.

Section 2.12 Cooperation and Delegation. The Governing Board shall have the right and authority at any time, from time to time, to enter into agreements and otherwise cooperate with, and/or delegate to, any other architectural review committees, or one or more other boards or committees, in order to increase consistency or coordination, reduce costs, or as may otherwise be deemed appropriate or beneficial by the Governing Board in its discretion. The costs and expenses for all such matters, if any, shall be shared or apportioned between such other boards or committees and the Metropolitan District, as the Governing Board may determine in its discretion from time to time. Additionally, the Governing Board shall have the right and authority at any time, from time to time, to enter into agreements and otherwise cooperate with, and/or delegate to, other architectural review committees, or one or more other boards or committees, to collect fees, charges, or other amounts which may be due to such entity and to permit any such entity to collect fees, charges, or other amounts which may be due to the Metropolitan District; in any such instance, the Governing Board shall provide for remittance to such entity of any amounts collected by the Governing Board or to the Metropolitan District of any amounts collected by such entity.

Section 2.13 Access Easement. Each Lot is subject to an easement in favor of the ARC and the Metropolitan District, including their agents, representatives, employees and contractors thereof: for performing any of the actions contemplated in this Declaration, including without limitation Sections 2.9 and 2.11 hereof; and/or for and incidental to investigation and/or enforcement of any term or provision of any of the Project Documents. If damage is inflicted, or a strong likelihood exists that it will be inflicted, on any of the Property, including without limitation any Lot, the Owner responsible for the damage or expense to avoid damage, or the Metropolitan District if it is responsible, is liable for the cost of prompt repair and remediation. Further, the rights and easements granted in this Section may be exercised only during reasonable hours after reasonable notice to the Owner(s) or occupant(s) of any affected Lot; except that no such notice shall be required in connection with any exterior, non-intrusive matter; and except that in emergency situations entry upon a Lot may be made at any time provided that the Owner(s) or occupant(s) of each affected Lot shall be notified of emergency entry as early as is reasonably possible. The interior of any residence located on a Lot shall not be subject to the easements provided for in this Section.

Section 2.14 No Liability. The Metropolitan District, the Governing Board, the ARC, and the members thereof, as well as any representative of the Metropolitan District, the Governing Board and the ARC appointed to act on its behalf, shall not be liable in equity or damages to any Person submitting requests for approval or to any Person by reason of any action, failure to act, approval, disapproval, or failure to approve or disapprove, in regard to any matter within its jurisdiction hereunder. In reviewing any matter, the Metropolitan District, the Governing Board, and the ARC shall not be responsible for the safety, whether structural or otherwise, of the Improvements submitted for review, nor the conformance with applicable building codes or other governmental laws or regulations, nor compliance with any other standards or regulations, and any approval of an Improvement by the Metropolitan District, the Governing Board, or the ARC shall not be deemed an approval of any such matters. No Owner or other Person shall be a third party beneficiary of any obligation imposed upon, rights accorded

to, action taken by, or approval granted by the Metropolitan District, the Governing Board, or the ARC.

Section 2.15 Variance. The ARC, in its sole discretion, may grant reasonable variances or adjustments from any conditions and restrictions imposed by this Declaration, in order to overcome practical difficulties or prevent unnecessary hardships arising by reason of the application of any such conditions and restrictions. Such variances or adjustments shall be granted only in case the granting thereof shall not be materially detrimental or injurious to the other real estate and Improvements in the neighborhood and shall not militate against the general intent and purpose hereof. In the event the Town requires a variance, said variance shall be granted in advance of submitting a request for variance to the ARC. Town approval of a variance does not obligate the ARC to also grant the same variance or adjustment.

Section 2.16 Waivers; No Precedent. The approval or consent of the ARC, or any representative thereof, to any application for approval shall not be deemed to constitute a waiver of any right to withhold or deny approval or consent by the ARC or any representative thereof, as to any application or other matters whatsoever as to which approval or consent may subsequently or additionally be required. Nor shall any such approval or consent be deemed to constitute a precedent as to any other matter.

ARTICLE III RESTRICTIONS

Section 3.1 Restrictions Imposed. The Property is subject to all requirements, covenants, restrictions and other matters stated on the recorded plats of the Property, or any portion thereof, as well as all other applicable documents. In addition, the Declarant declares that all of the Property shall be held and shall henceforth be sold, conveyed, used, improved, occupied, owned, resided upon and hypothecated, subject to the following provisions, conditions, limitations, restrictions, agreements and covenants, as well as those contained elsewhere in this Declaration. In addition, no unlawful use shall be permitted or made of the Property, or any portion thereof. All laws, ordinances and regulations of all governmental bodies having jurisdiction over the Property, or any portion thereof, shall be observed.

Section 3.2 Residential Use; Professional or Home Occupation. Lots shall be used for residential use only, including uses which are customarily incidental thereto, and shall not be used at any time for business, commercial or professional purposes. Notwithstanding the foregoing, however, Owners may conduct business activities within their homes provided that all of the following conditions are satisfied:

3.2.1 the business conducted is clearly secondary to the residential use of the home and is conducted entirely within the home;

3.2.2 the existence or operation of the business is not detectable from outside of the home by sight, sound, smell or otherwise, or by the existence of one or more signs indicating that a business is being operated; the Property;

3.2.3 the business does not result in an undue volume of traffic or parking within the Property;

3.2.4 the business conforms to all zoning requirements and is lawful in nature; and

3.2.5 the business conforms to this Declaration and the Guidelines, as well as any rules and regulations that may be imposed by the Metropolitan District, the Governing Board or the ARC from time to time.

Section 3.3 Household Pets. No animals, livestock, birds, poultry, reptiles or insects of any kind shall be raised, bred, kept or boarded in the Property; provided, however, that the Owners and residents of each Lot may keep a reasonable number of bona fide household pets (including dogs, cats or other domestic animals), or poultry (per Town codes), so long as such pets are not kept for any commercial purpose and are not kept in such number or in such manner as to create a nuisance to any resident of the Property. All household pets shall be controlled by their Owner and shall not be allowed off the Owner's Lot except when properly leashed and accompanied by the Owner or his or her representative, who shall be responsible for collecting and properly disposing of any animal waste. The ARC shall have, and is hereby given, the right and authority to determine in its sole discretion that dogs, cats or other household pets or poultry are being kept for commercial purposes or are being kept in such number or in such manner as to be unreasonable or to create a nuisance; or that an Owner or resident is in violation of the leash laws of the applicable jurisdiction or other applicable governmental laws, ordinances, or other provisions related to household pets and/or poultry; or that an Owner or resident is otherwise in violation of the provisions of this Section. In any such case, the ARC may take such action(s) as it may deem appropriate. An Owner's right to keep household pets and/or poultry shall be coupled with the responsibility to pay for any damage caused by such animals, as well as any costs incurred as a result of such animals. All Household Pets and/or poultry must be kept and their care shall be in compliance with and shall meet the Town Code Requirements. It shall be the responsibility of the Owners to verify and check local and current Town Codes and maintain their compliance with any and all applicable Ordinances, Rules and Regulations related thereto.

Section 3.4 Temporary Structures; Unsightly Conditions. Except as hereinafter provided, no structure of a temporary character, including, but not limited to, a tent, shack, storage shed, or outbuilding, shall be placed or erected; provided, however, that during the actual construction, alteration, repair or remodeling of a structure or other Improvements, necessary temporary structures for storage of materials may be erected and maintained by the Person doing such work. The work of constructing, altering or remodeling any structure or other Improvements shall be prosecuted diligently from the commencement thereof until the completion thereof. Further, no unsightly conditions, structures, facilities, equipment or objects shall be so located on the Property as to be visible from a street or any other portion of the Property. Notwithstanding any provisions herein contained to the contrary, it shall be expressly permissible for Declarant, its agents, employees, and contractors, or a builder with the express written approval of the Declarant, to maintain during the period of construction and sale of any Lots, upon such portion of the Property as Declarant may choose, such facilities as in its sole opinion may be reasonably required, convenient or incidental to the construction and sale or

rental of Lots, including, without limitation, a business office, storage area, construction yard, signs, model homes, sales office, construction office, parking areas, and lighting.

Section 3.5 Miscellaneous Requirements and Improvements.

3.5.1 *Signs and Advertising.* No advertising or signs of any character shall be erected, placed, permitted, or maintained other than a name plate of the occupant and a street number, and except for a "For Sale," "Open House," "For Rent," or security sign of not more than five (5) square feet in the aggregate, and such other signs, for such length(s) of time, which have the prior written approval of the ARC or are expressly permitted by applicable law. Notwithstanding the foregoing, signs, advertising, or billboards used by the Declarant (or by any builder with the express written consent of the Declarant) in connection with the sale or rental of Lots, or otherwise in connection with development of or construction on the Property, shall be permissible.

3.5.2 *Dog Runs, etc.* No clotheslines, drying yards, service yards, wood piles, storage areas or chain-linked (or other) dog runs, shall be so located as to be visible from a street or from the ground level of any Lot. Dog runs shall not be located within five (5) feet from any property line, and shall be screened by approved materials so that the dog therein is not visible from neighboring Lots. "Invisible" electric fences shall generally be permitted along property lines.

3.5.3 *HVAC.* No types of refrigerating, cooling or heating apparatus shall be permitted on a roof. Further, no such apparatus shall be permitted elsewhere except when appropriately screened from view of adjacent property owners and approved by the ARC. Without limiting the foregoing, conventional air conditioning units located on the ground of a Lot are permissible when approved by the ARC.

3.5.4 *Antenna.* Except as may otherwise be permitted by the ARC, no exterior radio antenna, television antenna, or other antenna, satellite dish (of greater than one (1) meter in size), or audio or visual reception device of any type shall be placed, erected or maintained, except inside a residence or otherwise concealed from view; provided, however, that any such devices may be erected or installed by the Declarant (or by any builder with the express written consent of the Declarant) in connection with the sale or rental of Lots, or otherwise in connection with development of or construction on the Property; and provided further, however, that the requirements of this subsection shall be subject to the Telecommunications Act of 1996 and applicable regulations, as amended from time to time.

3.5.5 *Fences.* Other than fences which may be constructed, installed or located by the Declarant (or by a builder with the express written approval of the Declarant) in its development or construction of Improvements in the Property, no fences shall be permitted except with the prior written approval of the ARC. No screening or fencing shall exceed five (5) feet in height, except fencing adjacent to major roadways, which may be six (6) feet in height. Any fences constructed on a Lot shall be maintained by the Owners of such Lot.

3.5.6 *Wind Generators.* No wind generators shall be constructed, installed, erected or maintained.

3.5.7 *Sheds*. Sheds shall be permitted if: the shed is in accordance with the Guidelines and any rules and regulations or similar provisions; and the shed has the prior, written approval of the ARC.

3.5.8 *Astroturf*. Not allowed without prior written approval of the ARC.

3.5.9 *Bird Houses and Feeders*. ARC approval is not required if limited to one (1) foot by two (2) feet and if not more than two in number are installed on any Lot. A birdhouse or birdfeeder may not be attached to the fence.

3.5.10 *Additional Guidelines*. The Governing Board of the Metropolitan District is authorized to promulgate design and/or architectural standards, rules, regulations and/or guidelines (collectively the "Guidelines"). Any such Guidelines may be included in rules and regulations promulgated by the Metropolitan District as set forth in Section 6.1 of this Declaration ("Rules and Regulations"). These Guidelines, as may be amended from time to time, shall be enforceable by the District and ARC, and are incorporated herein by reference as if fully set forth herein.

Section 3.6 Vehicular Parking, Storage and Repairs.

3.6.1 Except as otherwise provided in subsection 3.6.2 hereof and/or in rules and regulations which may be adopted by the Governing Board or the ARC from time to time, vehicles shall be parked only in the garages and driveways, if any, serving the Lots, or in appropriate spaces or areas which may be designated by the Governing Board or the ARC from time to time, except that any vehicle may be otherwise parked as a temporary expedient for loading, delivery, or emergency. Vehicles shall be subject to such reasonable rules and regulations as the Governing Board or the ARC may adopt from time to time. The Declarant (or a builder with the express written approval of the Declarant) may designate certain parking areas for visitors or guests, and the Governing Board or the ARC may adopt reasonable rules and regulations, from time to time, governing traffic or parking areas.

3.6.2 Except as may otherwise be set forth in the rules and regulations or Guidelines, or as otherwise required by law, commercial vehicles, vehicles with commercial writing or "Logos" on the exterior of the vehicles less than 24 square inches on each side and the rear of the vehicle, vehicles primarily used or designed for commercial purposes, tractors, mobile homes, recreational vehicles, trailers (either with or without wheels), campers, camper trailers, boats and other watercraft, recreational vehicles, golf carts, boats and boat trailers, junk cars, cars that are not capable of moving on their own power, and buses shall be parked only in enclosed garages or specific areas, if any, which may be designated by the Governing Board from time to time. Additionally, Commercial Vehicles are also subject to the following restrictions:

(a) No Commercial Vehicles 1 ton or larger, or any vehicles that have mechanical devices (crane, bucket/boom, fueling tanks, tow truck lifts, generators, etc.) attached to them, shall be parked or stored in the Districts, except as provided in enclosed garages or specific areas (if any) designated by the Governing Board. No truck shall have fuel storage tanks on board or any hazardous material by DOT standards. You will be asked to remove such commercial vehicles from the Districts.

(b) Commercial Vehicles used by the homeowner for daily commuting with commercial writing (Logo's) on their exterior front doors/sides/tail gate and or in window glass area that is a one (1) ton truck or smaller (Car) can have a small logo on each front door/sides/tail gate no larger than 24" by 24" measuring the sticker or magnetic sign from edge to edge. There shall be no parking for advertising allowed on cars, vans and or trucks. Racking systems (Ladder racks) on commercial vehicles are allowed in the District, with ladders side by side, although there shall be no stacking of ladders and no exposed material storage.

(c) Emergency vehicles (Police, Fire, (Government) or Volunteer are exempt from these restrictions. Volunteer vehicles will need documentation. Commercial Trucks/cars that do not meet these guidelines will be asked to park outside of the District's boundaries.

(d) These restrictions, however, shall not restrict trucks or commercial vehicles that are necessary for construction or for the maintenance of any portion of the Property or any Improvements located thereon, nor shall such restriction prohibit vehicles that may be otherwise parked as a temporary expedient for loading, delivery or emergency. Stored vehicles and vehicles which are inoperable or do not have current operating licenses shall not be permitted in the Property except within enclosed garages. For purposes of this Section, a vehicle shall be considered "stored" if, for example, it is up on blocks or covered with a tarpaulin and remains on blocks or so covered for seventy-two (72) consecutive hours without the prior approval of the Governing Board. This provision is intended to be broadly interpreted to cover almost any type of vehicle or structure not intended for every-day use. However, trailers, campers, motor homes, pickups, coaches, tents, or boats, which are entirely screened from view from the adjoining street or a neighboring house, or are stored completely within a garage, and are not used for living purposes, will not be in violation of these restrictions. The fact that a vehicle of the above description may be licensed by the State of Colorado or any other state as a passenger vehicle shall in no way exempt it from this provision or the general intent of this provision.

3.6.3 In the event the Governing Board determines that a vehicle is parked or stored in violation of subsections 3.6.1 or 3.6.2 hereof, then a written notice describing said vehicle shall be personally delivered to the owner thereof (if such owner can be reasonably ascertained) or shall be conspicuously placed upon the vehicle (if the owner thereof cannot be reasonably ascertained), and if the vehicle is not removed within a reasonable time thereafter, as determined by the Governing Board in its discretion from time to time, the Governing Board shall have the right to remove or boot the vehicle at the sole expense of the owner thereof. If a vehicle is parked in a fire lane, is blocking another vehicle or access to another Owner's or occupant's Lot or dwelling, is obstructing the flow of traffic, is parked on any grassy area, or otherwise creates a hazardous condition, no notice shall be required and the vehicle may be towed or booted immediately. If a vehicle is towed or booted in accordance with this Section, neither the Governing Board, nor any agent of the Metropolitan District shall be liable to any Person for towing and storage costs or for any claim of damage as a result of the towing or booting activity. The Governing Board's right to tow or boot is in addition to, and not in limitation of, all other rights of the Governing Board, including the right to assess fines. Notwithstanding anything to the contrary in this Section, the Governing Board may elect to impose fines or use other available sanctions, rather than exercise its authority to tow or boot.

3.6.4 No activity such as, but not limited to, maintenance, repair, rebuilding, dismantling, repainting or servicing of any kind of vehicles, trailers or boats, may be performed or conducted in the Property unless it is done within completely enclosed structure(s) which screen the sight and sound of the activity from the street and from adjoining real estate and Improvements. The foregoing restriction shall not be deemed to prevent washing and polishing of any motor vehicle, boat, trailer, motor-driven cycle, or other vehicle on a Lot, together with those activities normally incidental and necessary to such washing and polishing.

Section 3.7 Nuisances. No nuisance shall be permitted which is visible within or otherwise affects any portion of the Property, nor any use, activity or practice that interferes with the peaceful enjoyment or possession and proper use of any Lot, or any portion thereof, by its residents. As used herein, the term “nuisance” shall include each violation of any of the Project Documents, but shall not include any activities of the Declarant, the Developer, or a builder with the express written consent of the Declarant. No noxious or offensive activity shall be carried on, nor shall anything be done or placed on any Lot that is or may become a nuisance or cause embarrassment, disturbance or annoyance to others.

Section 3.8 No Hazardous Activities; No Hazardous Materials or Chemicals. No activities shall be conducted which are or might be unsafe or hazardous to any Person, real estate or Improvements. Without limiting the generality of the foregoing, no firearms shall be discharged and no open fires shall be lighted or permitted except in a contained barbecue unit while attended and in use for cooking purposes or within a fireplace. Further, no hazardous materials or chemicals shall at any time be located, kept or stored except such as may be contained in household products normally kept at homes for use of the residents thereof and in such limited quantities so as to not constitute a hazard or danger to Person, real estate or Improvements.

Section 3.9 No Annoying Light, Sounds or Odors. No light shall be emitted which is unreasonably bright or causes unreasonable glare; no sound shall be emitted which is unreasonably loud or annoying; and no odor shall be permitted which is noxious or offensive to others. Further, no annoying light, sound or odor shall be permitted which may be seen, heard or smelled from any Lot. In addition to the foregoing, no electromagnetic, light or any physical emission which might interfere with aircraft, navigation, communications or navigational aids shall be permitted.

Section 3.10 Restrictions on Trash and Materials. No refuse, garbage, trash, lumber, grass, shrubs or tree clippings, plant waste, metal, bulk materials, scrap, construction material or debris of any kind shall be kept, stored, or allowed to accumulate except inside the residence on any Lot nor shall such items be deposited on a street, unless placed in a suitable, tightly-covered container that is suitably located solely for the purpose of garbage pickup. Further, no trash or materials shall be permitted to accumulate in such a manner as to be visible from any Lot. All equipment for the storage or disposal of such materials shall be kept in a clean and sanitary condition. No garbage or trash cans or receptacles shall be maintained in an exposed or unsightly manner.

Section 3.11 Lots to be Maintained. Each Lot shall at all times be kept in a clean and slightly condition by the Owner(s) thereof. In the event accumulation of debris or growth of

weeds is not properly maintained by the Owner the District shall retain the right to enter the Lot and mow, collect and remove debris or otherwise maintain the Lot, and the Owner of the Lot shall pay expenses incurred by the District to the District.

Section 3.12 Leases. The term “lease,” as used herein, shall include any agreement for the leasing or rental of a Lot, or any portion thereof, and shall specifically include, without limitation, month-to-month rentals and subleases. Any Owner shall have the right to lease his Lot, or any portion thereof, as long as all leases provide that the terms of the lease and lessee’s occupancy of the leased premises shall be subject in all respects to the provisions of the Project Documents; and that any failure by the lessee to comply with any of the Project Documents, in any respect, shall be a default under the lease.

Section 3.13 Completion of Landscaping. Within the time frames as hereinafter provided, the Owner (other than the Declarant, or a builder with the express written approval of the Declarant) of each Lot shall install landscaping on all of the Lot which is not covered or enclosed by a building, fence or other structure, and shall thereafter maintain such landscaping in a neat and attractive condition, including periodic and professionally correct pruning, removal of weeds, and replacement of landscaping. The Owner of each Lot (other than Declarant, or a builder with the express written approval of the Declarant) shall install landscaping on such Lot within one hundred eighty (180) calendar days after the completion of construction of Improvements on such Lot by such Owner if said completion occurs between April 1 and October 1; if said completion does not occur between such dates, then such landscaping shall be installed by such Owner by the following October 1. Landscaping plans and other required documents shall be in accordance with the Guidelines, and shall be submitted to the ARC for review and approval prior to the installation of landscaping, except where installed by the Declarant, the Developer, or a builder with the express written approval of the Declarant. If any Owner fails to comply with this Section, or with the requirements of the ARC in installation or maintenance of landscaping, the Metropolitan District or the ARC may, at the direction of the Governing Board, enter upon such Lot and install or maintain landscaping for which the Owner shall be obligated to pay, retain the Compliance Deposit until the landscaping is completed or levy a fine against the Owner for non-compliance.

3.13.1 *Landscaping Plans*. For any Lot an additional review fee and Compliance Deposit must be paid to the ARC with submission of a landscaping plan. Landscaping plans may be submitted with the Construction Drawings but must be submitted and approved **PRIOR TO COMMENCEMENT OF LANDSCAPING**. Plans must depict fences, decks, sod, seeded areas, retaining walls, rock, timbers, sprinkler system, sizes and species of nursery materials, and include a drainage and grading plan that coincides with the builder’s, and shows any Improvements or alterations thereto. Landscape plans must be done by a professional landscape designer/contractor.

Section 3.14 Maintenance of and Non-Interference with Grade and Drainage.

3.14.1 Each Owner shall maintain the grading upon his Lot (including grading around the building foundation) at the slope and pitch fixed by the final grading thereof, including landscaping and maintenance of the slopes, so as to maintain the established drainage. Each Owner agrees that he will not in any way interfere with the established drainage pattern

over his Lot. In the event that it is necessary or desirable to change the established drainage over any Lot, then the Owner thereof shall submit a plan to the ARC for its review and approval, in accordance with the provisions of Article 2 of this Declaration and any such change shall also be made in accordance with all laws, regulations and resolutions of any applicable governmental entities. Further, each Owner acknowledges that any such change may affect or void any warranties. For purposes of this Section, “established drainage” is defined as the drainage, which exists at the time final grading of a Lot by, the Developer or a builder is completed.

ARTICLE IV

RESERVATION OF DEVELOPMENT RIGHTS

Section 4.1 Declarant and Builder Exemption. Notwithstanding anything to the contrary contained in any of the Project Documents, the Declarant (and any builder designated in writing by Declarant) shall be exempt from the Project Documents, including without limitation the requirement to obtain design approval from the ARC and any covenants or restrictions. Notwithstanding the foregoing, neither the Declarant nor any builder shall be exempt from the requirement to obtain approval from all governmental entities with jurisdiction over the Property.

Section 4.2 General Provisions. Declarant, for a period of twenty (20) years from and after the recording in the real estate records of Weld County, Colorado, of the final plat of the final filing within the Property, will have the following development rights (collectively, the “Development Rights”) with respect to all of the Property:

4.2.1 *Period of Declarant Control*. Declarant shall have the right to maintain its position as Declarant hereunder and shall have the right to exercise any and all rights, duties and powers granted herein to the District at any time during the Period of Declarant Control. Such right, duty or power shall be automatic, without any need for formal action being taken to evidence the same. Accordingly, all reference herein to the District shall, to the extent appropriate be construed to mean and refer equally to Declarant during the Period of Declarant Control. Notwithstanding anything set forth herein to the contrary, Declarant shall have all rights of an Owner hereunder.

4.2.2 *Completion of Improvements*. The right to complete or make Improvements as indicated on any Plat filed with respect to the Property.

4.2.3 *Annexation*. The right at any time, from time to time, to annex to the Property additional real estate and Improvements, including without limitation any real estate and Improvements which may previously have been withdrawn from the Property. By each such annexation, if any, the Declarant shall be deemed to have amended the term “Property” to include such annexed real estate and Improvements. Each such annexation, if any, shall be accomplished by recording of a Supplemental Declaration adding such Parcel, recorded in the real property records of the Clerk and Recorder of the County where the Property is located. Such Supplemental Declaration will expressly and unequivocally provide that the real estate and Improvements described therein shall be subject to this Declaration and all terms and provisions hereof. Any such annexation may include provisions, which, as to the real estate and Improvements described therein, adds to or changes the rights, responsibilities and other requirements of this Declaration.

4.2.4 *Create Lots.* The right to create Lots on the Property.

4.2.5 *Subdivide Lots.* The right to subdivide Lots on any part of the Property, and the right to relocate boundaries between Lots.

4.2.6 *Common Areas.* The right to create additional common areas, to convert Lots into common areas, or to convert common areas into Lots, on all or any portion of the Property.

4.2.7 *Withdrawal.* The right to withdraw the Property, or any portion thereof, from this Declaration so long as the Declarant owns the portion of the Property to be withdrawn. By each such withdrawal, if any, the Declarant shall be deemed to have amended the term "Property" to exclude such withdrawn real estate and Improvements. The right to withdraw any portion(s) of the Property includes the right to withdraw one or more Lots, or other portion(s) of the Property, at different times and from time to time. Each withdrawal, if any, may be affected by the Declarant recording a withdrawal document in the office of the Clerk and Recorder of the county in which such withdrawn real estate and Improvements are located. A withdrawal as contained in this paragraph constitutes a divestiture, withdrawal, and de-annexation of the withdrawn real estate and Improvements from this Declaration so that, from and after the date of recording a withdrawal document, the real estate and Improvements so withdrawn shall not be part of the Property. If real estate is withdrawn from the Property ("Withdrawn Property"):

(a) The owner(s) of the Withdrawn Property shall have whatever easements are necessary or desirable, if any, for access, utility service, repair, maintenance and emergencies over and across the common areas within the Property.

(b) The owner(s) within the Property shall have whatever easements are necessary or desirable, if any, for access, utility service, repair, maintenance and emergencies over and across the common areas within the Withdrawn Property.

(c) Declarant shall prepare and record in the real property records of county where the applicable real estate is located whatever documents are necessary to evidence such easements. Such recorded easement(s) shall specify that the owners of the Withdrawn Property and the owners of the Property shall be obligated to pay a proportionate share of the cost of the operation and maintenance of any easements utilized by either one of them on the other's property upon such reasonable basis as the Declarant shall establish in the easement(s). Preparation and recordation by Declarant of an easement pursuant to this Section shall conclusively determine the existence, location and extent of the reciprocal easements that are necessary or desirable as contemplated by this Section.

4.2.8 *Merger.* The right to merge or consolidate the Property with another community of the same form of ownership.

4.2.9 *Sales and Construction Activities.* The right, for Declarant and any builder (but only with the express written consent of the Declarant), and their employees, agents, and contractors to perform, from time to time, and to maintain upon portions of the Lots, such activities and materials as Declarant or such builder deems necessary or incidental to the

construction and sale of Lots and development and construction of Improvements. The foregoing includes, without limitation, locating, maintaining and relocating management offices, construction trailers, construction offices, signs, model units and sales offices, in such numbers, of such sizes, and at such locations as it determines in its discretion from time to time. Construction activities shall be in compliance with and not exceed times permitted for construction as provided in the Town Code. Further, nothing contained in any of the Project Documents shall limit the rights of Declarant or a builder, with Declarant's express written approval:

(a) to excavate, cut, fill or grade any real estate (with the consent of the Owner thereof) or to construct, alter, demolish or replace any Improvements;

(b) to use any Improvements on any real estate (with the consent of the Owner thereof) as a construction, management, model home, sales or leasing office in connection with the development, construction or sale of any real estate and/or Improvements; and/or for any other activity.

(c) to seek or obtain any approvals under any of the Project Documents association.

4.2.10 *Master Association.* The right to make the Property subject to a master association.

4.2.11 *Dedications.* The right to establish, from time to time, by dedication or otherwise, public streets, utility and other easements for purposes including, but not limited to, public access, access, paths, walkways, drainage, recreation areas, parking areas, ducts, shafts, flues, conduit installation areas, and to create other reservations, exceptions and exclusions.

4.2.12 *Use Agreements.* The right to enter into, establish, execute, amend, and otherwise deal with contracts and agreements for the use, lease, repair, maintenance or regulations of parking and/or recreational facilities and/or common area, which may or may not be a part of the Property.

4.2.13 *Site Plan Modification/Expansion.* Nothing in this Declaration shall preclude the Declarant from modifying any Site Plan, subject to the approval of the required governmental authorities, including but not limited to the purpose of expanding the square footage of Improvements permitted to be constructed on the Lots owned by Declarant, provided that such modification does not have a material and adverse impact on any Lot not owned by Declarant, and does not violate any then-existing zoning, land use, or other requirements of the Town or County in which the Property is located or any other governmental entity having jurisdiction.

Section 4.3 Supplemental Provisions Regarding Development Rights. Without limiting the generality of the foregoing, certain of these Development Rights are explained more fully in this Article below. Further, Declarant reserves the right to amend this Declaration and any Plat in connection with the exercise of any Development Rights, and Declarant also reserves

the additional rights retained for the benefit of Declarant in this Article and in other provisions of this Declaration.

Section 4.4 Utility Easements. Declarant hereby reserves for itself and its successors and assigns a general easement upon, across, over, in, and under the Property for ingress and egress and for installation, replacement, repair and maintenance of all utilities, including, but not limited to, water, sewer, gas, telephone, and electrical, cable and other communications systems. By virtue of this easement, it shall be expressly permissible and proper for the companies providing such services to install and maintain necessary equipment, wires, circuits, and conduits under and over the Property. No water, sewer, gas, telephone, electrical, communications or other utility or service lines, systems or facilities may be installed or relocated on the surface of the Property, unless approved by the ARC. These items may be temporarily installed above ground during construction, if approved by the ARC, subject to the requirements, if any, of any governmental authority having jurisdiction over the Property.

Section 4.5 Drainage Easements. Declarant reserves for itself and its successors and assigns an easement to enter on any portion of the Property for the purpose of modifying the grade of any drainage channels on the Property to improve the drainage of water. Every Lot shall be burdened with easements for natural drainage of storm water runoff from the other portions of the Property; provided, no Person shall alter the natural drainage on any Lot so as to materially increase the drainage of water onto adjacent portions of the Property without the consent of the ARC and the Owner of the affected property.

Section 4.6 General Provision. Any Person using these general easements provided under Sections 4.4 and 4.5 above shall use its best efforts to install and maintain the easements for utilities or drainage without disturbing the uses of the Owners and the Declarant; shall prosecute its installation and maintenance activities as promptly as reasonably possible; and in the case of utility work, shall restore the surface to its original condition as soon as possible after completion of its work, and shall comply with all requirements of the Guidelines and the ARC. Should any Person furnishing a service covered by these general easements request a specific easement by separate recordable document, Declarant shall have, and is hereby given the right and authority, with the prior approval of the ARC, to grant such easement upon, across, over, or under any part or all of the Property without conflicting with the terms of this Declaration. This general easement shall in no way affect, void, extinguish, or modify any other recorded easement affecting the Property.

Section 4.7 Reservation for Construction. Declarant hereby reserves for itself and its successors and assigns a perpetual easement and right-of-way over, upon and across the Property for construction, utilities, drainage, and ingress and egress. Declarant may make the location of these easements and rights-of-way certain with the prior approval of the ARC, by instruments recorded in the real estate records of Weld County, Colorado. Declarant further reserves the right to establish from time to time, by dedication or otherwise, utility and other easements, reservations, exceptions and exclusions necessary or convenient for the development, use and operation of any other property of Declarant, as long as such action is approved by the ARC and does not hamper the enjoyment of the Property by the Owners.

Section 4.8 Rights Incidental to the Construction Easement. Declarant expressly reserves the right to perform construction work and to store materials in secure areas, in Lots owned by it and in the common areas and the future right to control such work and repairs, and the right of access thereto, until its completion. Declarant may perform all work without the consent or approval of any Owner or mortgagee. Declarant reserves an easement through the common areas as may be reasonably necessary for the purpose of discharging Declarant's obligations and exercising Declarant's Development Rights reserved in this Declaration. Such easement includes the right to construct underground utility lines, pipes, wires, ducts, conduits, and other facilities across the land not designated as reserved for future development in this Declaration or on any Plat for the purpose of furnishing utility and other services to the property so reserved for future development. Declarant's reserved construction easement includes the right to grant easements to public utility companies and to convey Improvements within those easements anywhere in the common areas.

Section 4.9 Maintenance Easement. A blanket easement is hereby reserved to Declarant for the benefit of the Declarant, Declarant's Affiliates, successors and specific assigns, and granted to the Metropolitan District and any member of the Governing Board or ARC, and their respective officers, agents, employees, contractors and assigns, upon, across, over, in and under the Property and any Lot, and a right to make such use of the Property or Lot as may be necessary or appropriate to make repairs or to perform the duties, obligations, functions and maintenance which the Metropolitan District, the Governing Board, or the ARC are obligated or permitted to perform pursuant to the Project Documents, including the right to enter upon any Lot for the purpose of performing maintenance and repair thereon, as required by this Declaration, together with the right of access, ingress and egress necessary for such installation, maintenance, operation, repair, replacement and upkeep.

Section 4.10 Operations and Maintenance Services and Costs. The Declarant hereby authorizes the Metropolitan District to provide certain operations and maintenance services to the Property in lieu of a homeowners' association (as may be authorized or limited by law and the Service Plan for the Districts), which services may include, operation and maintenance of any District pools, clubhouse, recreation center or recreation facilities, open space, common areas, greenbelts, landscaped medians, monuments, entry features, fencing, landscape buffers and setbacks, ponds, lakes, trails, paths and walkways, non-potable irrigation water facilities and improvements, detention/retention ponds and drainage facilities, covenant enforcement and architectural/design review services, and operations and maintenance services for public facilities and improvements not otherwise dedicated to the Town in accordance with Approved Development Plans. Each Lot Owner may be charged an annual fee, for operation and maintenance services provided by the Metropolitan District as described herein. The annual fee shall subject to adjustment at the discretion of and as determined by the Governing Board of the Metropolitan District based upon the Metropolitan District's annual budget, and amendments thereto from time to time. The Board of Directors of the District shall not be liable for any omission or improper exercise by any Agent or independent contractor of any duty, power or function so delegated by written instrument executed by or on behalf of the Board of Directors of the District.

Section 4.11 Recorded Easements. In addition to all easements and rights-of-way of record at or before the recording of this Declaration, the Property, and all portions thereof, shall

be subject to the easements as shown on any recorded Plat of the Property, or any portion thereof, and the easements established in this Declaration.

Section 4.12 Emergency Easement. A general easement is hereby granted to all police, sheriff, fire protection, ambulance and all other similar emergency agencies or Persons to enter upon all streets and upon the Property in the proper performance of their duties.

Section 4.13 Easements Deemed Appurtenant. Any and all conveyances made by Declarant to any Owner shall be conclusively deemed to incorporate these reservations of rights and easements, whether or not set forth in such grants. The easements and rights created herein for an Owner shall be deemed appurtenant to the Lot owned by such Owner. All conveyances and instruments affecting title to a Lot shall be deemed to grant and reserve the easements and rights of way as provided herein, as though set forth in said document in full, even though no specific reference to such easements or rights of way appear.

Section 4.14 Order of Exercise of Development Rights. The fact that Declarant may exercise one or more of Declarant's Development Rights on one portion of the Property will not operate to require Declarant to exercise a Development Right with respect to any other portion of the Property. The Declarant may exercise its Development Rights on all or any portion of the Property in whatever order of development the Declarant, in its sole discretion, determines.

Section 4.15 Rights Transferable. Any Development Rights created or reserved under this Article or elsewhere in this Declaration for the benefit of the Declarant may be transferred to any Person by an instrument describing the rights transferred and recorded in the real estate records of Weld County, Colorado. Such instrument shall be executed by the transferor (Declarant) and the transferee.

ARTICLE V

RELEASE, WAIVER AND CERTAIN DISCLOSURES

Section 5.1 Minor Violations of Setback Restrictions. If upon the erection of any structure, it is disclosed by survey that a minor violation or infringement of proposed setback or offset lines has occurred, such violation or infringement shall be deemed waived by the Owners of each Lot immediately adjoining the structure which is in violation of the setback or offset, and such waiver shall be binding upon all other Owners. However, nothing contained in this Section shall prevent the prosecution of a suit for any other violation of the Covenants or the Guidelines, if any. A "minor violation," for the purpose of this Section, is a violation of not more than one (1) foot beyond the proposed setback or offset lines, so long as there is no encroachment into the established minimum setbacks and offsets determined by the Guidelines, Plat and Town policies. Any encroachment into the minimum established setback or offset area shall require a Variance. This provision shall apply only to the original structures and shall not be applicable to any alterations or repairs to, or replacements of, any of such structures. The release and waiver set forth in Section 5.6 (Waiver) shall apply to this Section.

Section 5.2 Limitation on Liability. The Declarant, the Metropolitan District, the Governing Board, the ARC, and their directors, officers, shareholders, partners, members, agents and employees, shall not be liable to any Person for any action or for any failure to act arising

out of this Declaration or the Project Documents, unless the action or failure to act was not in good faith and was done or withheld with malice. The release and waiver set forth in Section 5.6 (Waiver) shall apply to this Section.

Section 5.3 No Representations, Guaranties or Warranties. No representations, guaranties or warranties of any kind, express or implied, shall be deemed to have been given or made by the Declarant, the Metropolitan District, the Governing Board, the ARC or by any of their officers, directors, shareholders, members, partners, agents or employees, in connection with any portion of the Property, or any Improvement, its physical condition, structural integrity, freedom from defects, zoning, compliance with applicable laws, fitness for intended use, or view, or in connection with the subdivision, sale, operation, maintenance, cost of maintenance, taxes or regulation thereof, unless and except as specifically set forth in writing. The release and waiver set forth in Section 5.6 (Waiver) shall apply to this Section.

Section 5.4 Disclaimer Regarding Safety.

THE DECLARANT, THE METROPOLITAN DISTRICT, THE GOVERNING BOARD, THE ARC, AND THEIR OFFICERS, DIRECTORS, SHAREHOLDERS, MEMBERS, PARTNERS, AGENTS AND EMPLOYEES, HEREBY DISCLAIM ANY OBLIGATION REGARDING THE SECURITY OF ANY PERSONS OR PROPERTY WITHIN THE PROPERTY. BY ACCEPTING A DEED TO A LOT WITHIN THE PROPERTY, EACH OWNER ACKNOWLEDGES THAT THE DECLARANT, THE METROPOLITAN DISTRICT, THE GOVERNING BOARD, THE ARC, AND THEIR OFFICERS, DIRECTORS, SHAREHOLDERS, MEMBERS, PARTNERS, AGENTS AND EMPLOYEES, ARE OBLIGATED TO DO ONLY THOSE ACTS SPECIFICALLY ENUMERATED HEREIN OR IN THE COVENANTS AND GUIDELINES, IF ANY, AND ARE NOT OBLIGATED TO DO ANY OTHER ACTS WITH RESPECT TO THE SAFETY OR PROTECTION OF PERSONS OR PROPERTY WITHIN THE PROPERTY. THE RELEASE AND WAIVER SET FORTH IN SECTION 5.6 (WAIVER) SHALL APPLY TO THIS SECTION.

Section 5.5 Development Within and Surrounding the Property. Each Owner acknowledges that development within and surrounding the Property may continue for an indefinite period, and that plans for the density, type and location of Improvements, developments or land uses may change over time. Such development may entail changes to or alterations in the access to the Property, view of or from the Property or the Lots, surrounding land uses, open space or facilities, traffic volumes or patterns, privacy or other off-site aspects or amenities. Development also may entail noise, odors, unsightliness, dust and other inconveniences or disruptions. By accepting a deed to a Lot, each Owner accepts title to such Lot subject to the foregoing, and waives and releases any claim against the Declarant, the Metropolitan District, the Governing Board, the ARC, and their respective officers, directors, members, partners, agents and employees, heirs, personal representatives, successors and assigns, arising out of or associated with any of the foregoing. The release and waiver set forth in Section 5.6 (Waiver) shall apply to this Section.

Section 5.6 Waiver. By acceptance of a deed to a Lot, each Owner hereby releases, waives, and discharges the Declarant, the Metropolitan District, the Governing Board, the ARC,

and their respective officers, directors, members, partners, agents and employees, heirs, personal representatives, successors and assigns, from all losses, claims, liabilities, costs, expenses, and damages, arising directly or indirectly from any hazards, disclosures or risks set forth in this Declaration, and any Guidelines, rules and regulations, and other documents now or hereafter adopted by or for the Metropolitan District, including without limitation, those contained in Sections 5.1 through 5.5 of this Declaration.

Section 5.7 Colorado Governmental Immunity Act. Notwithstanding anything to the contrary, the parties hereto understand and agree that liability for claims for injuries to persons, real estate or Improvements arising out of the negligence of the Metropolitan District, its boards, officials, and employees, is controlled and limited by the provisions of the Colorado Governmental Immunity Act, §24-10-101, et seq. C.R.S. and §24-30-1501, et seq. C.R.S. Any provision of this Declaration, whether or not incorporated herein by reference, shall be controlled, limited and otherwise modified so as to limit any liability of the Metropolitan District to the above-cited laws.

ARTICLE VI **GENERAL PROVISIONS**

Section 6.1 Rules and Regulations. Rules and regulations concerning and governing the Property may be adopted, enacted, modified, amended, repealed, and re-enacted from time to time by the Governing Board and the ARC. Any such rules and regulations may be included in Guidelines promulgated by the ARC as set forth in Section 2.4 herein. Such rules and regulations may be incorporated into this Declaration. The rules and regulations may state procedural requirements, interpretations, clarifications and applications of this Declaration and law, including without limitation, blanket requirements, blanket interpretations, and blanket applications. The Governing Board and the ARC have the authority to adopt or vary one or more rules and regulations that are different for different types of Lots, if any. Any rules and regulations that are adopted shall be in accordance with, and shall not be inconsistent with or contrary to, this Declaration.

Section 6.2 Enforcement.

6.2.1 Enforcement of the covenants, conditions, restrictions, easements, reservations, and other provisions contained in this Declaration, as amended, may be by any proceeding at law or in equity against any Person(s) violating or attempting to violate any such provision. The Metropolitan District, the Governing Board, the ARC, and any aggrieved Owner shall have the right to institute, maintain and prosecute any such proceedings. No remedy shall be exclusive of other remedies that may be available. In any action instituted or maintained under this Declaration or any other Project Documents, the prevailing party shall recover its costs and attorney fees incurred in asserting or defending the claim, as well as any and all other sums. Failure by the Metropolitan District, the Governing Board, the ARC, or any Owner (including without limitation the Declarant) to enforce any covenant, restriction or other provision shall in no event be deemed a waiver of the right to do so thereafter.

6.2.2 Without limiting the generality of the foregoing, the Metropolitan District, the Governing Board, and/or the ARC shall have the right to send demand letters and

notices, to levy and collect fines, to negotiate, settle and to take any and all other actions with respect to any violation(s) or alleged violation(s) of any of the Project Documents.

6.2.3 The decision of the Metropolitan District, the Governing Board or the ARC to pursue enforcement action in any particular case shall be left to their discretion, subject to the duty to exercise judgment and be reasonable, and further restricted in that the Metropolitan District, the Governing Board or the ARC shall not be arbitrary or capricious in taking enforcement action. A decision of the Metropolitan District, the Governing Board or the ARC not to pursue enforcement action shall not be construed as a waiver of their right to enforce such provisions at a later time under other circumstances or preclude them from enforcing any other covenant, restriction or rule. Without limiting the generality of the foregoing, the Metropolitan District, the Governing Board or the ARC may determine that, under the circumstances of a particular case:

(a) the Metropolitan District's, the Governing Board's or the ARC's legal position is not strong enough to justify taking any or further action;

(b) the covenant, restriction or rule being enforced is, or is likely to be construed as, inconsistent with applicable law; or

(c) that it is not in the Metropolitan District's, the Governing Board's or the ARC's best interest, based upon hardship, expense, limited effect on other Owners or other reasonable criteria, to pursue enforcement action.

Section 6.3 Duration, Amendment and Supplement.

6.3.1 Each and every provision of this Declaration shall run with and bind the Property perpetually from the date of recording of this Declaration. Subject to subsection 6.3.2 of this Section, this Declaration may be amended and/or supplemented by the affirmative vote or agreement of the Owners of sixty-seven percent (67%) of the Lots. Notwithstanding the foregoing, the Metropolitan District shall not be required to comply with or enforce any such Owner adopted amendments or supplements to this Declaration until such time as the Metropolitan District receives a recorded copy of such amendment and/or supplement in compliance with Section 6.5 of this Declaration (Notices).

6.3.2 Notwithstanding anything to the contrary, until twenty (20) years after conveyance of all the Property to the first Owners thereof other than the Declarant, no amendment or supplement of this Declaration shall be effective without the prior written approval of the Declarant.

6.3.3 Notwithstanding anything to the contrary, this Declaration may be amended in whole or in part, at any time from time to time, by the Declarant without the consent or approval of any other Owner, the Metropolitan District, or any other Person, in order to comply with the requirements, standards, or guidelines of any recognized secondary mortgage markets, the department of housing and urban development, the federal housing administration, the veterans administration, the federal home loan mortgage corporation, the government national mortgage association, or the federal national mortgage association.

6.3.4 Notwithstanding anything to the contrary, this Declaration may be amended in whole or in part, at any time from time to time, by the Declarant without the consent or approval of any other Owner, the Metropolitan District, or any other Person, in order to correct any clerical, typographical or technical errors in this Declaration or to clarify any provision of this Declaration.

6.3.5 Notwithstanding anything to the contrary, this Declaration may be amended in whole or in part, at any time from time to time, by the Declarant without the consent or approval of any other Owner, the Metropolitan District, or any other Person, in order to comply with the requirements of any applicable law in the event any provision contained herein does not so comply.

6.3.6 Subsections 6.3.2, 6.3.3, 6.3.4 and 6.3.5 of this Section shall not be amended or deleted without the prior written approval of the Declarant.

Section 6.4 Severability. All provisions of this Declaration are severable. Invalidation of any provision of this Declaration by judgment, court order or otherwise, shall in no way affect or limit any other provisions which shall remain in full force and effect.

Section 6.5 Notices. Any notice permitted or required in this Declaration shall be deemed to have been given and received upon the earlier to occur of (a) personal delivery upon the Person to whom such notice is to be given; or (b) two (2) days after deposit in the United States mail, registered or certified mail, postage prepaid, return receipt requested, addressed to the Owner at the address for such Owner's Lot.

Section 6.6 Headings. The Article, Section and subsection headings in this Declaration are inserted for convenience of reference only, do not constitute a part of this Declaration, and in no way define, describe or limit the scope or intent of this Declaration or any of the provisions hereof.

Section 6.7 Gender. Unless the context requires a contrary construction, the singular shall include the plural and the plural the singular and the use of any gender shall be applicable to all genders.

Section 6.8 Runs with the Land; Binding Upon Successors. The benefits, burdens, and all other provisions contained in this Declaration shall be covenants running with and binding upon the Property and all Improvements which are now or hereafter become a part of the Property and any Future Parcel(s). The benefits, burdens, and all other provisions contained in this Declaration shall be binding upon, and inure to the benefit of the Metropolitan District, the Declarant, the Developer, and all Owners, and upon and to their respective heirs, personal representatives, successors and assigns.

IN WITNESS WHEREOF, the undersigned, being the Declarant herein has hereunto set its hand this 8th day of December, 2017.

DECLARANT:

Conestoga Developers Company, LLC
A Colorado Limited Liability Company

By:

Its:

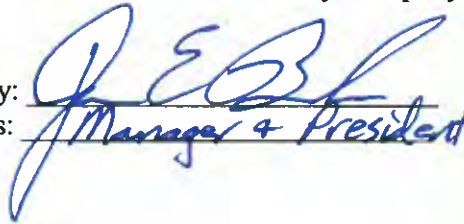

Manager + President

STATE OF COLORADO)
) ss.
COUNTY OF WELD)

On this 8th day of December, 2017, before me, a Notary Public, personally appeared Jamie Baessler in his capacity as Manager of Conestoga Developers Company, LLC, a Colorado limited liability company, to me known to be the person described in and who executed the foregoing instrument, and acknowledged that he executed the same in the indicated capacity as his free act and deed.

Witness my hand and seal of office.

My commission expires: 2/5/2020

[SEAL]

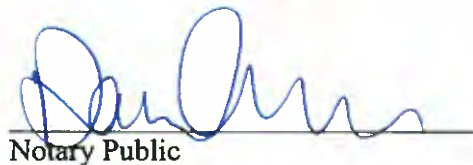

Notary Public

DARCYCHILTON
NOTARYPUBLIC
STATE OF COLORADO
NOTARY ID 20164004865
MY COMMISSION EXPIRES 2-5-2020

**OWNER'S CONSENT TO SUBROGATION
OF CERTAIN REAL PROPERTY
TO
DECLARATION OF COVENANTS, CONDITIONS,
RESTRICTIONS, AND EASEMENTS
FOR
THE CONESTOGA PUD**

A portion of the Property currently is owned by _____ ("_____"). For good and valuable consideration, the receipt and sufficiency of which is hereby acknowledged, and as evidenced by signature below, _____ hereby consents to subject his portion of the Property to the covenants, conditions, restrictions and easements described herein, which shall run with the land and be binding on _____, his heirs, successors, and assigns having any right, title or interest in all or any part of the portion of Property currently owned by _____.

So acknowledged and consented by:

[NAME]

STATE OF COLORADO)
)
COUNTY OF _____) ss.
)

The foregoing instrument was acknowledged before me this _____ day of _____, 2017, by _____.

Witness my hand and seal of office.

My commission expires: _____

[SEAL]

Notary Public

**METROPOLITAN DISTRICTS' CONSENT TO
DECLARATION OF COVENANTS, CONDITIONS,
RESTRICTIONS, AND EASEMENTS
FOR
THE CONESTOGA PUD**

For good and valuable consideration the receipt and sufficiency of which is hereby acknowledged, the undersigned, as the Metropolitan Districts charged with covenant enforcement and architectural review services under this Declaration, hereby consent to subjection of the Property to this Declaration and all the terms and provisions hereof.

Executed this _____ day of _____, 2017.

CONESTOGA METROPOLITAN DISTRICT NOS. 1 THROUGH 4

By: _____
Jaimie Baessler, Chairman

STATE OF COLORADO)
) ss.
COUNTY OF _____)

The foregoing instrument was acknowledged before me this _____ day of _____, 2017, by Jaimie Baessler, as Chairman of CONESTOGA METROPOLITAN DISTRICT NO. 1, NO. 2, NO. 3, NO. 4 and NO. 5

Witness my hand and seal of office.

My commission expires: _____

[S E A L]

Notary Public

**EXHIBIT A TO
DECLARATION OF COVENANTS, CONDITIONS, RESTRICTIONS AND
EASEMENTS
FOR CONESTOGA**

(Legal Description of Conestoga Metropolitan District No. 1)

(Legal Description of Conestoga Metropolitan District No. 2)

(Legal Description of Conestoga Metropolitan District No. 3)

(Legal Description of Conestoga Metropolitan District No. 4)

(Legal Description of Conestoga Metropolitan District No. 5)

EXHIBIT A

PROPERTY DESCRIPTION

Conestoga Metro District #1

A parcel of land being a portion of Lots 1 and Outlot 1, Block 5 of the First Replat of Conestoga Subdivision First Filing as recorded March 12, 2008 as Reception No. 3541114 of the Records of Weld County, together with a portion of Overland Trail Right of Way as dedicated by action of said First Replat of Conestoga Subdivision First Filing, situate in the Southeast Quarter (SE1/4) of Section Eleven (11), Township Seven North (T.7N.), Range Sixty-six West (R.66W.), Sixth Principal Meridian (6th P.M.), Town of Ault, County of Weld, State of Colorado and being more particularly described as follows:

COMMENCING at the Center Quarter corner of said Section 11 and assuming the North line of said SE1/4 as bearing North 89°08'51" East being a Grid bearing of the Colorado State Plane Coordinate System, North Zone, North American Datum 1983/2011, a distance of 2711.19 feet with all other bearings contained herein relative thereto;

THENCE North 89°08'51" East along said North line a distance of 751.13 feet to the **POINT OF BEGINNING**;

THENCE North 89°08'51" East along said North line a distance of 30.00 feet;

THENCE South 00°51'09" East a distance of 105.00 feet;

THENCE South 89°08'51" West a distance of 30.00 feet;

THENCE North 00°51'09" West a distance of 105.00 feet to the North line of the SE1/4 of said Section 11 and to the **POINT OF BEGINNING**.

Said described parcel of land contains 3,150 Square Feet or 0.072 Acres, more or less (±) and is subject to any rights-of-way or other easements of record or as now existing on said described parcel of land.

SURVEYORS STATEMENT

I, Ronnie L. Edwards, a Colorado Licensed Professional Land Surveyor do hereby state that this Parcel Description was prepared under my personal supervision and checking, and that it is true and correct to the best of my knowledge and belief.

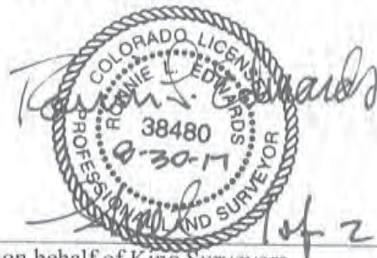

Ronnie L. Edwards - on behalf of King Surveyors
Colorado Licensed Professional
Land Surveyor #38480

KING SURVEYORS
650 East Garden Drive
Windsor, Colorado 80550
(970) 686-5011

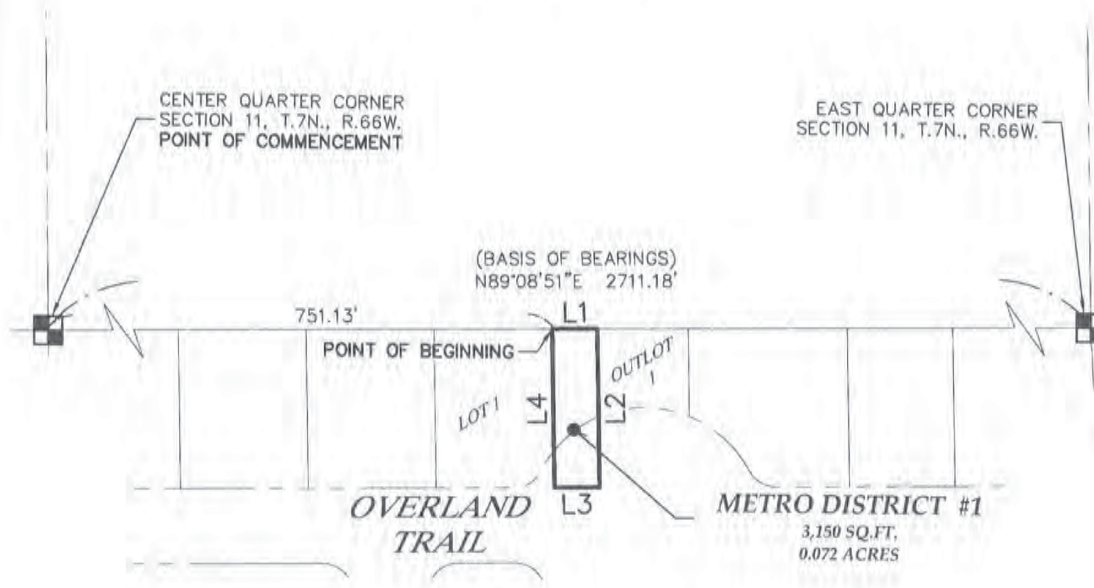

LINE TABLE		
LINE	BEARING	LENGTH
L1	N89°08'51"E	30.00'
L2	S00°51'09"E	105.00'
L3	S89°08'51"W	30.00'
L4	N00°51'09"W	105.00'

Ronnie L. Edwards
 COLORADO LICENSE #38480
 8-30-17
 PROFESSIONAL LAND SURVEYOR
 2 of 2

Ronnie L. Edwards – On Behalf Of King Surveyors
 Colorado Licensed Professional
 Land Surveyor #38480

NOTE: This exhibit drawing is not intended to be a monumented land survey. It's sole purpose is as a graphic representation to aid in the visualization of the written property description which it accompanies. The written property description supersedes the exhibit drawing.

NOTICE: According to Colorado law you must commence any legal action based upon any defect in this survey within three years after you first discover such defect. In no event may any action based upon any defect in this survey be commenced more than ten years from the date of the certification shown hereon. (13-80-105 C.R.S. 2012)

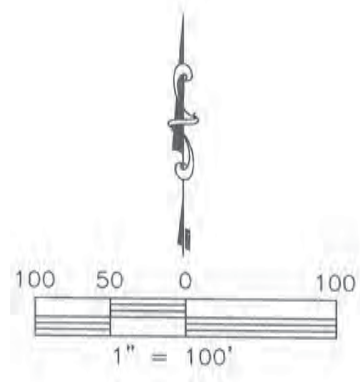

KING SURVEYORS
 650 E. Garden Drive | Windsor, Colorado 80550
 phone: (970) 686-5011 | fax: (970) 686-5821
 email: contact@KingSurveyors.com

PROJECT NO: 20170417
DATE: 08-30-2017
CLIENT: GENESIS DEVELOPMENT MANAGEMENT
DWG: 20170417DIST1
DRAWN: TJJ **CHECKED:** RLE

EXHIBIT A

PROPERTY DESCRIPTION

Conestoga Metro District #2

Multiple parcels of land being a portion of the First Replat of Conestoga Subdivision First Filing as recorded March 12, 2008 as Reception No. 3541114 of the Records of Weld County, situate in the Southeast Quarter (SE1/4) of Section Eleven (11), Township Seven North (T.7N.), Range Sixty-six West (R.66W.), Sixth Principal Meridian (6th P.M.), Town of Ault, County of Weld, State of Colorado and being more particularly described as follows:

PARCEL A

COMMENCING at the South Quarter corner of said Section 11 and assuming the West line of said SE1/4 as bearing North 00°31'51" West being a Grid bearing of the Colorado State Plane Coordinate System, North Zone, North American Datum 1983/2011, a distance of 2696.30 feet with all other bearings contained herein relative thereto;

THENCE North 00°31'51" West along said West line a distance of 395.40 feet to the **POINT OF BEGINNING**;

THENCE North 00°31'51" West along said West line a distance of 865.01 feet;

THENCE North 89°08'57" East a distance of 109.86 feet;

THENCE South 00°32'07" East a distance of 7.67 feet;

THENCE North 89°27'52" East a distance of 320.00 feet;

THENCE North 00°32'08" West a distance of 322.73 feet;

THENCE North 89°27'53" East a distance of 263.00 feet;

THENCE North 81°13'36" East a distance of 254.07 feet;

THENCE North 17°31'06" East a distance of 63.07 feet to the Northerly line of Tract B of said First Replat of Conestoga Subdivision First Filing and to a point hereinafter referred to as **POINT "A"**;

THENCE North 88°09'32" East along said Northerly line a distance of 78.86 feet to the Westerly Right of Way line of Conestoga Drive as dedicated by action of said First Replat of Conestoga Subdivision First Filing;

THENCE South 03°08'50" East along said Westerly Right of Way line a distance of 473.39 feet to a Point of Curvature (PC), said line also being the Easterly line of Tract A & Tract B of said First Replat of Conestoga Subdivision First Filing;

The following Ten (10) courses are along the Easterly lines of said Tract A:

THENCE along the arc of a curve concave to the Northeast a distance of 211.15 feet, said curve has a Radius of 280.00 feet, a Delta of 43°12'28" and is subtended by a Chord that bears South 24°45'04" East a distance of 206.19 feet to a Point of Tangency (PT);

THENCE South 46°21'18" East a distance of 96.70 feet to a PC;

THENCE along the arc of a curve concave to the Southwest a distance of 20.71 feet, said curve has a Radius of 20.00 feet, a Delta of 59°19'21" and is subtended by a Chord bearing South 16°41'38" East a distance of 19.79 feet to a Point of Reverse Curvature (PRC);

THENCE along the arc of a curve concave to the Northeast a distance of 39.00 feet, said curve has a Radius of 78.00 feet, a Delta of 28°38'43" and is subtended by a Chord bearing South 01°21'18" East a distance of 38.59 feet to a PRC;

THENCE along the arc of a curve concave to the Northwest a distance of 20.71 feet, said curve has a Radius of 20.00 feet, a Delta of 59°19'21" and is subtended by a Chord bearing South 13°58'34" West a distance of 19.79 feet to the end point of said curve;

THENCE South 46°21'18" East along a line non-tangent to the aforesaid curve a distance of 60.01 feet to the beginning point of a curve, non-tangent to this line;

THENCE along the arc of a curve concave to the Southeast a distance of 20.71 feet, said curve has a Radius of 20.00 feet, a Delta of 59°19'21" and is subtended by a Chord bearing North 73°18'22" East a distance of 19.79 feet to a PRC;



THENCE along the arc of a curve concave to the Northwest a distance of 39.00 feet, said curve has a Radius of 78.00 feet, a Delta of 28°38'43" and is subtended by a Chord bearing North 88°38'42" East a distance of 38.59 feet to a PRC;

THENCE along the arc of a curve concave to the Southwest a distance of 20.71 feet, said curve has a Radius of 20.00 feet, a Delta of 59°19'21" and is subtended by a Chord bearing South 76°00'59" East a distance of 19.79 feet to a PT;

THENCE South 46°21'18" East a distance of 75.71 feet to a point hereinafter referred to as **POINT "B"**;

THENCE South 43°38'41" West a distance of 340.34 feet to a PC;

THENCE along the arc of a curve concave to the Southeast a distance of 90.60 feet, said curve has a Radius of 103.60 feet, a Delta of 50°06'25" and is subtended by a Chord that bears South 18°35'28" West a distance of 87.74 feet to the end point of said curve;

THENCE South 89°22'12" West along a line non-tangent to the aforesaid course a distance of 129.66 feet;

THENCE South 00°00'44" East a distance of 402.26 feet to the South line of Tract A of said First Replat of Conestoga Subdivision First Filing;

THENCE North 89°58'48" West along said South line a distance of 60.00 feet to the East line of that parcel of land described in that deed recorded June 26, 1991 as Reception No. 2254460 of the Records of Weld County;

The following Two (2) courses are along the East and North lines of said parcel of land described in that deed recorded June 26, 1991 as Reception No. 2254460 of the Records of Weld County:

THENCE North 00°00'44" West a distance of 239.93 feet;

THENCE South 89°47'44" West a distance of 340.66 feet;

THENCE North 00°12'15" West along the Northerly prolongation of the Westerly line of said parcel of land described in that deed recorded June 26, 1991 as Reception No. 2254460 of the Records of Weld County a distance of 109.97 feet;

THENCE South 89°28'03" West a distance of 367.23 feet to a PC;

THENCE along the arc of a curve concave to the Southeast a distance of 15.41 feet, said curve has a Radius of 43.00 feet, a Delta of 20°31'47" and is subtended by a Chord that bears South 79°12'10" West a distance of 15.33 feet to a PRC;

THENCE along the arc of a curve concave to the Northwest a distance of 60.30 feet, said curve has a Radius of 83.00 feet, a Delta of 41°37'45" and is subtended by a Chord that bears South 89°45'09" West a distance of 58.99 feet to a PT;

THENCE South 89°08'57" West a distance of 155.05 feet to the West line of the SE1/4 of said Section 11 and to the **POINT OF BEGINNING**.

Said described parcel contains 1,288,213 Square Feet or 29.573 Acres, more or less (±).

PARCEL B

TOGETHER WITH that parcel of land being a portion of the First Replat of Conestoga Subdivision First Filing as recorded March 12, 2008 as Reception No. 3541114 of the Records of Weld County, situate in the Southeast Quarter (SE1/4) of Section Eleven (11), Township Seven North (T.7N.), Range Sixty-six West (R.66W.), Sixth Principal Meridian (6th P.M.), Town of Ault, County of Weld, State of Colorado and being more particularly described as follows:

COMMENCING at the aforesaid **POINT "A"**;

The following Four (4) courses are along the Easterly lines of said Tract A:

THENCE North 01°50'28" West a distance of 100.14 feet;

THENCE South 84°29'35" West a distance of 14.82 feet;

THENCE North 07°51'51" West a distance of 50.00 feet;

THENCE North 06°15'38" West a distance of 66.73 feet;

THENCE North 46°58'44" West a distance of 51.50 feet;

THENCE North 35°46'48" West a distance of 297.00 feet;

THENCE North 32°21'20" East a distance of 127.22 feet to the beginning point of a curve, non-tangent to this course;

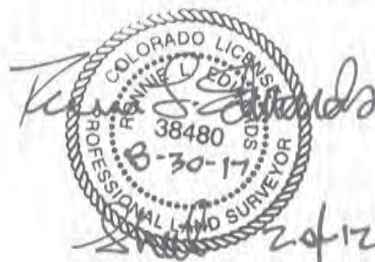

THENCE along the arc of a curve concave to the Southwest a distance of 12.11 feet, said curve has a Radius of 20.00 feet, a Delta of 34°41'34" and is subtended by a Chord that bears North 73°30'22" West a distance of 11.93 feet to the end point of said curve;

THENCE North 00°51'09" West along a line non-tangent to the aforesaid course a distance of 63.15 feet and to a PT;

THENCE along the arc of a curve concave to the Northwest a distance of 8.03 feet, said curve has a Radius of 20.00 feet, a Delta of 23°00'50" and is subtended by a Chord that bears North 07°40'35" East a distance of 7.98 feet to a PRC;

THENCE along the arc of a curve concave to the Northeast a distance of 14.55 feet, said curve has a Radius of 280.00 feet, a Delta of 02°58'41" and is subtended by a Chord that bears North 02°20'30" West a distance of 14.55 feet to a PT;

THENCE North 00°51'09" West a distance of 164.41 feet to a PC;

THENCE along the arc of a curve concave to the Southwest a distance of 31.42 feet, said curve has a Radius of 20.00 feet, a Delta of 90°00'00" and is subtended by a Chord that bears North 45°51'09" West a distance of 28.28 feet to the end point of said curve;

THENCE North 00°51'09" West along a line non-tangent to the aforesaid course a distance of 50.00 feet;

THENCE South 89°08'51" West a distance of 9.97 feet;

THENCE North 00°51'09" West a distance of 105.00 feet to the North line of the SE1/4 of said Section 11 and to the North line of said First Replat of Conestoga Subdivision First Filing;

The following Two (2) courses are along the North and East lines of said First Replat of Conestoga Subdivision First Filing:

THENCE North 89°08'51" East a distance of 699.31 feet;

THENCE South 02°56'21" East a distance of 783.52 feet to the Northeast corner of Lot 9, Block 3 of said First Replat of Conestoga Subdivision First Filing;

THENCE South 86°51'10" West along the North line of said Lot 9 and along the Westerly prolongation thereof a distance of 156.50 feet to a point on the Easterly line of Lot 14, Block 4 of said First Replat of Conestoga Subdivision First Filing;

The following Three (3) courses are along the Easterly, Northerly, and Westerly lines of said Lot 14:

THENCE North 03°08'50" West a distance of 24.07 feet;

THENCE South 86°51'10" West a distance of 120.00 feet;

THENCE South 03°08'50" East a distance of 10.95 feet to the Northeast corner of Lot 15, Block 4 of said First Replat of Conestoga Subdivision First Filing;

THENCE South 78°46'58" West along the North line of said Lot 15 and along the Westerly prolongation thereof a distance of 178.95 feet to the Easterly line of Lot 6, Block 8 of said First Replat of Conestoga Subdivision First Filing and to the beginning point of a curve, non-tangent to this course;

The following Two (2) courses are along the Easterly and Northerly lines of said Lot 6, Block 8:

THENCE along the arc of a curve concave to the Southwest a distance of 28.85 feet, said curve has a Radius of 220.00 feet, a Delta of 07°30'49" and is subtended by a Chord that bears North 14°58'25" West a distance of 28.83 feet to the end point of said curve;

THENCE South 71°16'25" West along a line non-tangent to the aforesaid course a distance of 94.48 feet to the **POINT OF BEGINNING**.

Said described parcel contains 538,510 Square Feet or 12.362 Acres, more or less (±).

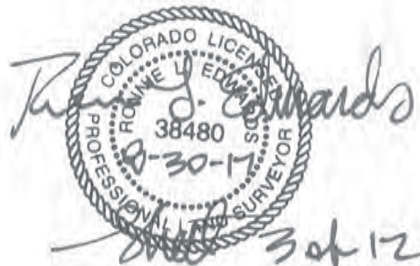

PARCEL C

TOGETHER WITH Tracts 1, Tract C, and a portion of Open Space A, of the First Replat of Conestoga Subdivision First Filing as recorded March 12, 2008 as Reception No. 3541114 of the Records of Weld County, situate in the Southeast Quarter (SE1/4) of Section Eleven (11), Township Seven North (T.7N.), Range Sixty-six West (R.66W.), Sixth Principal Meridian (6th P.M.), Town of Ault, County of Weld, State of Colorado and being more particularly described as follows:

COMMENCING at the aforesaid **POINT "B"**;

THENCE North 43°38'41" East a distance of 60.00 feet to the Southwesterly line of said Tract C and to the **POINT OF BEGINNING**;

The following Four (4) courses are along the Southwesterly lines of said Tract C:

THENCE North 46°21'18" West a distance of 75.71 feet to a PC;

THENCE along the arc of a curve concave to the Northeast a distance of 20.71 feet, said curve has a Radius of 20.00 feet, a Delta of 59°19'21" and is subtended by a Chord that bears North 16°41'38" West a distance of 19.79 feet to a PRC;

THENCE along the arc of a curve concave to the Southwest a distance of 43.55 feet, said curve has a Radius of 78.00 feet, a Delta of 31°59'17" and is subtended by a Chord that bears North 03°01'36" West a distance of 42.98 feet to a PRC;

THENCE along the arc of a curve concave to the Southeast a distance of 21.87 feet, said curve has a Radius of 20.00 feet, a Delta of 62°39'56" and is subtended by a Chord that bears North 12°18'44" East a distance of 20.80 feet to the end point of said curve and to the Southwesterly corner of said Tract 1;

The following Eight (8) courses are along the Southwesterly, Westerly and Northwest lines of said Tract 1:

THENCE North 46°21'18" West along a line non-tangent to the aforesaid curve a distance of 50.00 feet to the beginning point of a curve non-tangent to this course;

THENCE along the arc of a curve concave to the Northwest a distance of 21.87 feet, said curve has a Radius of 20.00 feet, a Delta of 62°39'56" and is subtended by a Chord that bears South 74°58'40" West a distance of 20.80 feet to a PRC;

THENCE along the arc of a curve concave to the Southwest a distance of 43.55 feet, said curve has a Radius of 78.00 feet, a Delta of 31°59'17" and is subtended by a Chord that bears North 89°41'01" West a distance of 42.98 feet to a PRC;

THENCE along the arc of a curve concave to the Northeast a distance of 20.71 feet, said curve has a Radius of 20.00 feet, a Delta of 59°19'21" and is subtended by a Chord that bears North 76°00'59" West a distance of 19.79 feet to a PT;

THENCE North 46°21'18" West a distance of 96.70 feet to a PC;

THENCE along the arc of a curve concave to the Northeast a distance of 165.91 feet, said curve has a Radius of 220.00 feet, a Delta of 43°12'28" and is subtended by a Chord that bears North 24°45'04" West a distance of 162.00 feet to a PT;

THENCE North 03°08'50" West a distance of 89.19 feet;

THENCE North 88°09'30" East a distance of 490.28 feet to the Northeast corner of said Tract C and to the beginning point of a curve non-tangent to this course, said line also being along the most Southerly Northerly line of Open Space A and along the Northerly line of said Tract C;



The following Eight (8) courses are along the Easterly, Southerly & Westerly lines of said Tract C:

THENCE along the arc of a curve concave to the Northeast a distance of 46.98 feet, said curve has a Radius of 235.00 feet, a Delta of 11°27'12" and is subtended by a Chord that bears South 10°52'44" East a distance of 46.90 feet to a PT;

THENCE South 16°37'26" East a distance of 170.87 feet to a PC;

THENCE along the arc of a curve concave to the Southwest a distance of 42.76 feet, said curve has a Radius of 175.00 feet, a Delta of 14°00'00" and is subtended by a Chord that bears South 09°37'26" East a distance of 42.65 feet to a PT;

THENCE South 02°37'26" East a distance of 297.19 feet to a PC;

THENCE along the arc of a curve concave to the Northwest a distance of 31.65 feet, said curve has a Radius of 20.00 feet, a Delta of 90°40'17" and is subtended by a Chord that bears South 42°42'42" West a distance of 28.45 feet to a PT;

THENCE South 88°02'51" West a distance of 46.05 feet to a PC;

THENCE along the arc of a curve concave to the Northeast a distance of 175.08 feet, said curve has a Radius of 220.00 feet, a Delta of 45°35'51" and is subtended by a Chord that bears North 69°09'14" West a distance of 170.50 feet to a PT;

THENCE North 46°21'18" West a distance of 33.68 feet to the **POINT OF BEGINNING**.

Said described parcel of land contains 219,709 Square feet or 5.044 acres, more or less (±).

Total of the described Parcels of land contains 2,046,432 Square Feet of 46.979 Acres, more or less (±) and is subject to and rights of way or other easements of record or as now existing on said described parcels of land.

SURVEYORS STATEMENT

I, Ronnie L. Edwards, a Colorado Licensed Professional Land Surveyor do hereby state that this Parcel Description was prepared under my personal supervision and checking, and that it is true and correct to the best of my knowledge and belief.



Ronnie L. Edwards - on behalf of King Surveyors
Colorado Licensed Professional
Land Surveyor #38480

KING SURVEYORS
650 East Garden Drive
Windsor, Colorado 80550
(970) 686-5011

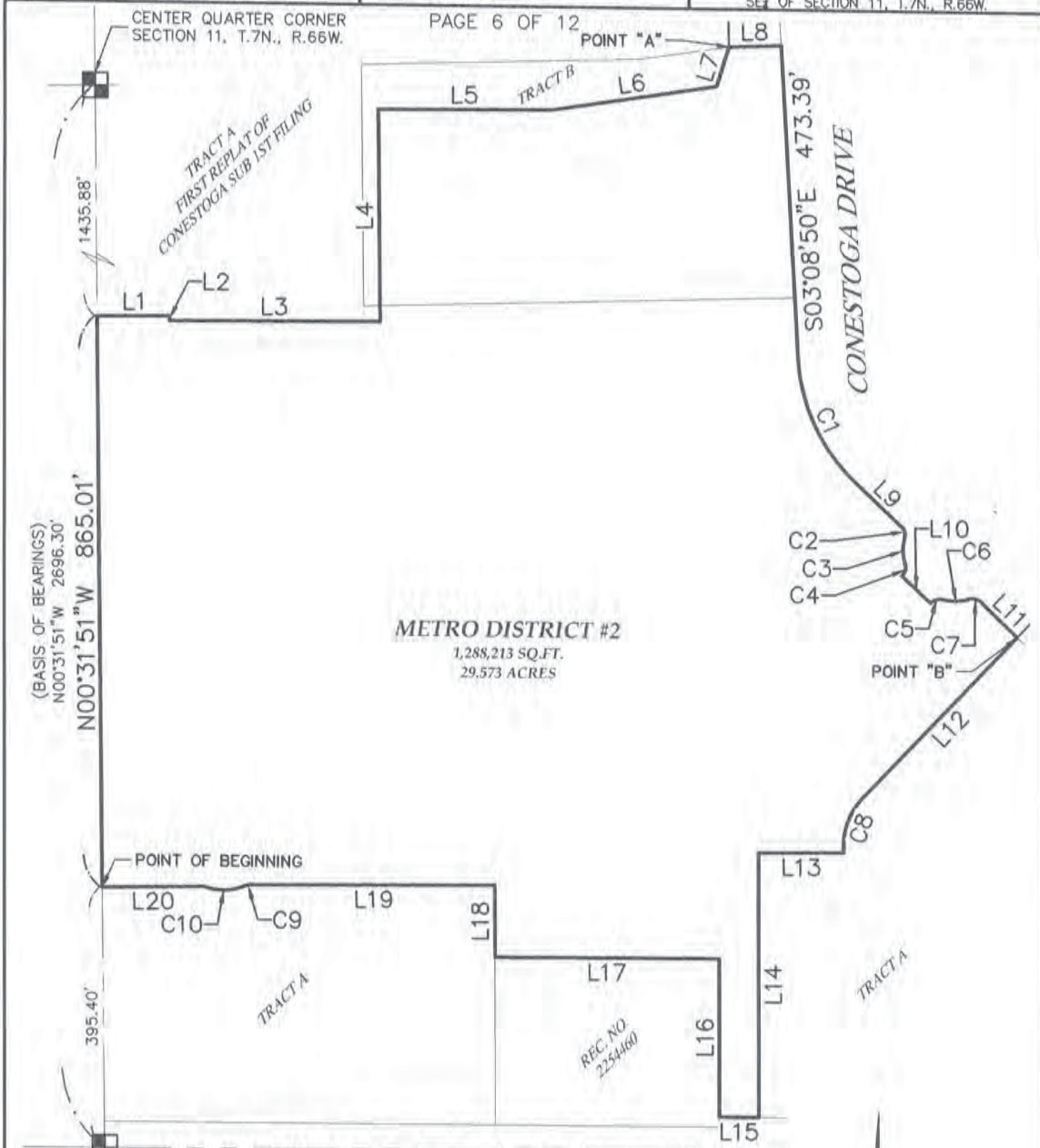

METRO DISTRICT #2
1,288,213 SQ.FT.
29.573 ACRES

(BASIS OF BEARINGS)
N00°31'51"W 865.01'

1435.88'

395.40'

S03°08'50"E 473.39'

Colorado Licensed Professional Land Surveyor
Ronnie L. Edwards
38480
8-30-17
Surveyor

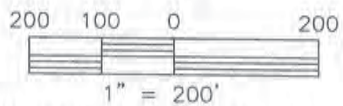

Ronnie L. Edwards - On Behalf Of King Surveyors
Colorado Licensed Professional
Land Surveyor #38480

NOTE: This exhibit drawing is not intended to be a monumented land survey. It's sole purpose is as a graphic representation to aid in the visualization of the written property description which it accompanies. The written property description supersedes the exhibit drawing.

NOTICE: According to Colorado law you must commence any legal action based upon any defect in this survey within three years after you first discover such defect. In no event may any action based upon any defect in this survey be commenced more than ten years from the date of the certification shown hereon. (13-80-105 C.R.S. 2012)



KING SURVEYORS
650 E. Garden Drive | Windsor, Colorado 80550
phone: (970) 686-5011 | fax: (970) 686-5821
email: contact@KingSurveyors.com

PROJECT NO: 20170417
DATE: 08-30-2017
CLIENT: GENESIS DEVELOPMENT MANAGEMENT
DWG: 20170417DIST2
DRAWN: TJJ CHECKED: RLE

NOTE: This exhibit drawing is not intended to be a monumented land survey. It's sole purpose is as a graphic representation to aid in the visualization of the written property description which it accompanies. The written property description supersedes the exhibit drawing.

NOTICE: According to Colorado law you must commence any legal action based upon any defect in this survey within three years after you first discover such defect. In no event may any action based upon any defect in this survey be commenced more than ten years from the date of the certification shown hereon. (13-80-105 C.R.S. 2012)

LINE TABLE		
LINE	BEARING	LENGTH
L1	N89°08'57"E	109.86'
L2	S00°32'07"E	7.67'
L3	N89°27'52"E	320.00'
L4	N00°32'08"W	322.73'
L5	N89°27'53"E	263.00'
L6	N81°13'36"E	254.07'
L7	N17°31'06"E	63.07'
L8	N88°09'32"E	78.86'
L9	S46°21'18"E	96.70'
L10	S46°21'18"E	60.00'
L11	S46°21'18"E	75.71'
L12	S43°38'41"W	340.34'
L13	S89°22'12"W	129.66'
L14	S00°00'44"E	402.26'
L15	N89°58'48"W	60.00'
L16	N00°00'44"W	239.93'
L17	S89°47'44"W	340.66'
L18	N00°12'15"W	109.97'
L19	S89°28'03"W	367.23'
L20	S89°08'57"W	155.05'

CURVE TABLE					
CURVE	LENGTH	RADIUS	DELTA	CHORD	CH BEARING
C1	211.15'	280.00'	43°12'28"	206.19'	S24°45'04"E
C2	20.71'	20.00'	59°19'21"	19.79'	N16°41'38"W
C3	39.00'	78.00'	28°38'43"	38.59'	S01°21'18"E
C4	20.71'	20.00'	59°19'21"	19.79'	N13°59'01"E
C5	20.71'	20.00'	59°19'21"	19.79'	S73°18'22"W
C6	39.00'	78.00'	28°38'43"	38.59'	N88°38'42"E
C7	20.71'	20.00'	59°19'21"	19.79'	N76°00'59"W
C8	90.60'	103.60'	50°06'25"	87.74'	S18°35'28"W
C9	15.41'	43.00'	20°31'47"	15.33'	S79°12'10"W
C10	60.30'	83.00'	41°37'45"	58.99'	N89°45'09"E

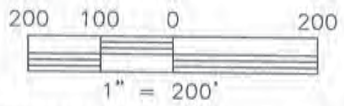

Ronnie L. Edwards -- On Behalf Of King Surveyors
Colorado Licensed Professional
Land Surveyor #38480



KING SURVEYORS

650 E. Garden Drive | Windsor, Colorado 80550
phone: (970) 686-5011 | fax: (970) 686-5821
email: contact@KingSurveyors.com

PROJECT NO: 20170417
DATE: 08-30-2017
CLIENT: GENESIS DEVELOPMENT MANAGEMENT
DWG: 20170417DIST2
DRAWN: TJJ **CHECKED:** RLE

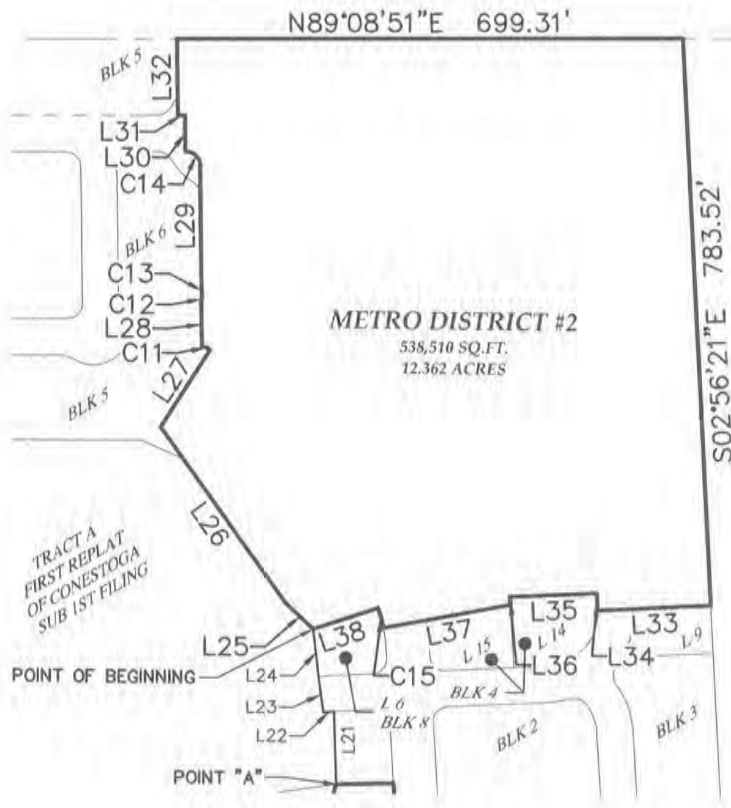

Ronnie L. Edwards
 COLORADO LICENSED PROFESSIONAL LAND SURVEYOR
 38480
 8-30-17
Bohiz

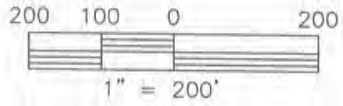

Ronnie L. Edwards - On Behalf Of King Surveyors
 Colorado Licensed Professional
 Land Surveyor #38480

NOTE: This exhibit drawing is not intended to be a monumented land survey. It's sole purpose is as a graphic representation to aid in the visualization of the written property description which it accompanies. The written property description supersedes the exhibit drawing.

NOTICE: According to Colorado law you must commence any legal action based upon any defect in this survey within three years after you first discover such defect. In no event may any action based upon any defect in this survey be commenced more than ten years from the date of the certification shown hereon. (13-80-105 C.R.S. 2012)



KING SURVEYORS
 650 E. Garden Drive | Windsor, Colorado 80550
 phone: (970) 686-5011 | fax: (970) 686-5821
 email: contact@KingSurveyors.com

PROJECT NO: 20170417
DATE: 08-30-2017
CLIENT: GENESIS DEVELOPMENT MANAGEMENT
DWG: 20170417DIST2
DRAWN: TJJ **CHECKED:** RLE

LINE TABLE		
LINE	BEARING	LENGTH
L21	N01°50'28"W	100.14'
L22	S84°29'35"W	14.82'
L23	N07°51'51"W	50.00'
L24	N06°15'38"W	66.73'
L25	N46°58'44"W	51.50'
L26	N35°46'48"W	297.00'
L27	N32°21'20"E	127.22'
L28	N00°51'09"W	63.15'
L29	N00°51'09"W	164.41'
L30	N00°51'09"W	50.00'
L31	S89°08'51"W	9.97'
L32	N00°51'09"W	105.00'
L33	S86°51'10"W	156.50'
L34	N03°08'50"W	24.07'
L35	S86°51'10"W	120.00'
L36	S03°08'50"E	10.95'
L37	S78°46'58"W	178.95'
L38	S71°16'25"W	94.48'

CURVE TABLE					
CURVE	LENGTH	RADIUS	DELTA	CHORD	CH BEARING
C11	12.11'	20.00'	34°41'34"	11.93'	N73°30'22"W
C12	8.03'	20.00'	23°00'50"	7.98'	N07°40'35"E
C13	14.55'	280.00'	2°58'41"	14.55'	N02°20'30"W
C14	31.42'	20.00'	90°00'00"	28.28'	N45°51'09"W
C15	28.85'	220.00'	7°30'49"	28.83'	N14°58'25"W

Ronnie L. Edwards
9 of 12

Ronnie L. Edwards – On Behalf Of King Surveyors
Colorado Licensed Professional
Land Surveyor #38480

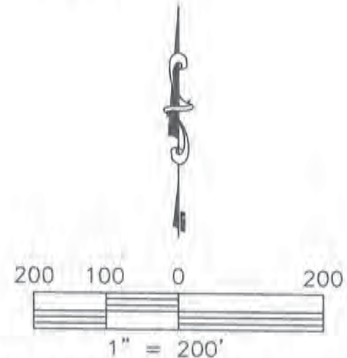

NOTE: This exhibit drawing is not intended to be a monumented land survey. It's sole purpose is as a graphic representation to aid in the visualization of the written property description which it accompanies. The written property description supersedes the exhibit drawing.

NOTICE: According to Colorado law you must commence any legal action based upon any defect in this survey within three years after you first discover such defect. In no event may any action based upon any defect in this survey be commenced more than ten years from the date of the certification shown hereon. (13-80-105 C.R.S. 2012)



KING SURVEYORS

650 E. Garden Drive | Windsor, Colorado 80550
phone: (970) 686-5011 | fax: (970) 686-5821
email: contact@KingSurveyors.com

PROJECT NO: 20170417

DATE: 08-30-2017

CLIENT: GENESIS DEVELOPMENT MANAGEMENT

DWG: 20170417DIST2

DRAWN: TJJ CHECKED: RLE

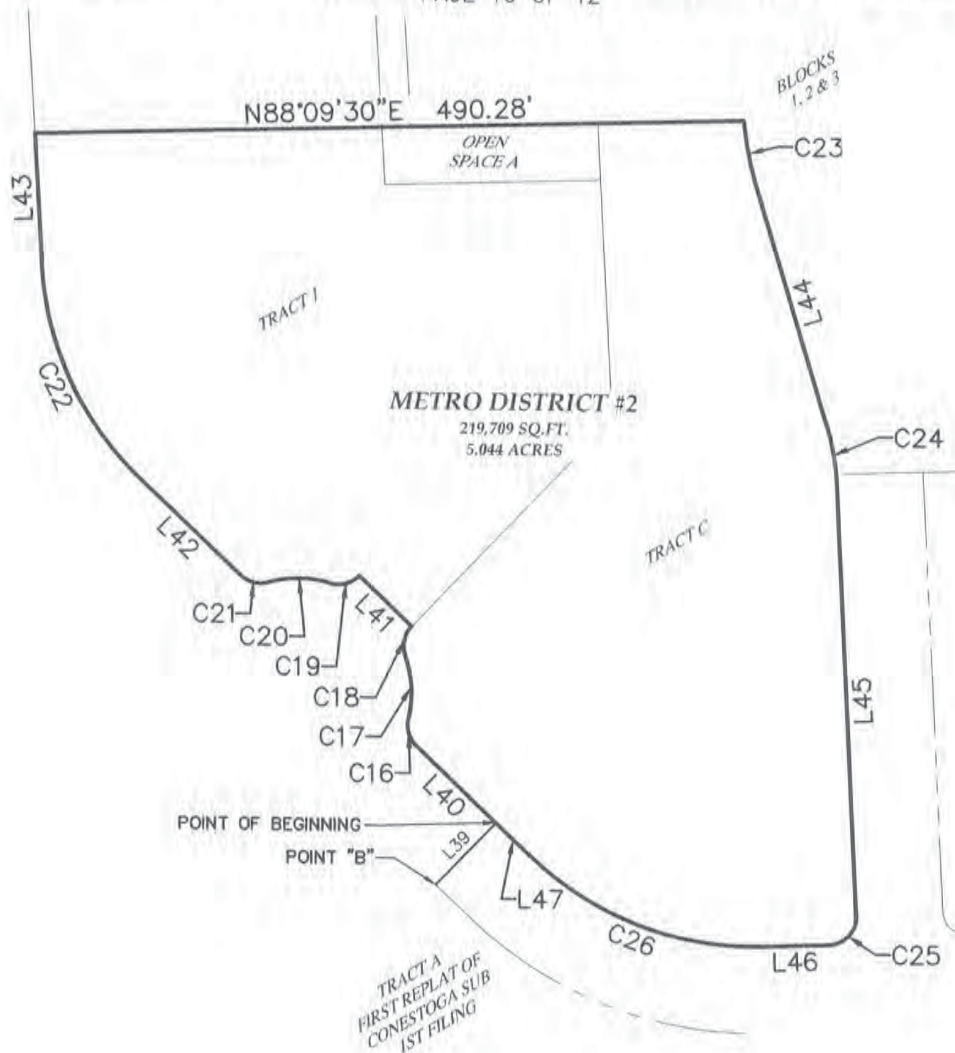

Ronnie L. Edwards

Ronnie L. Edwards - On Behalf Of King Surveyors
 Colorado Licensed Professional
 Land Surveyor #38480

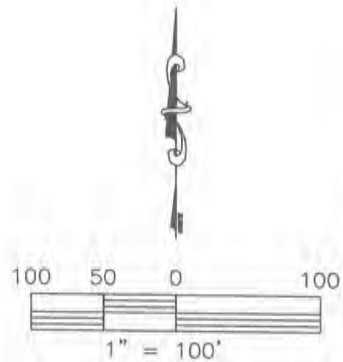

NOTE: This exhibit drawing is not intended to be a monumented land survey. It's sole purpose is as a graphic representation to aid in the visualization of the written property description which it accompanies. The written property description supersedes the exhibit drawing.

NOTICE: According to Colorado law you must commence any legal action based upon any defect in this survey within three years after you first discover such defect. In no event may any action based upon any defect in this survey be commenced more than ten years from the date of the certification shown hereon. (13-80-105 C.R.S. 2012)



KING SURVEYORS

650 E. Garden Drive | Windsor, Colorado 80550
 phone: (970) 686-5011 | fax: (970) 686-5821
 email: contact@KingSurveyors.com

PROJECT NO: 20170417

DATE: 08-30-2017

CLIENT: GENESIS DEVELOPMENT MANAGEMENT

DWG: 20170417DIST2

DRAWN: TJJ CHECKED: RLE

LINE TABLE		
LINE	BEARING	LENGTH
L39	N43°38'41"E	60.00'
L40	N46°21'18"W	75.71'
L41	N46°21'18"W	50.00'
L42	N46°21'18"W	96.70'
L43	N03°08'50"W	89.19'
L44	S16°37'26"E	170.87'
L45	S02°37'26"E	297.19'
L46	S88°02'51"W	46.05'
L47	N46°21'18"W	33.69'

CURVE TABLE					
CURVE	LENGTH	RADIUS	DELTA	CHORD	CH BEARING
C16	20.71'	20.00'	59°19'21"	19.79'	N16°41'38"W
C17	43.55'	78.00'	31°59'17"	42.98'	N03°01'36"W
C18	21.87'	20.00'	62°39'56"	20.80'	N12°18'44"E
C19	21.87'	20.00'	62°39'56"	20.80'	S74°58'40"W
C20	43.55'	78.00'	31°59'17"	42.98'	N89°41'01"W
C21	20.71'	20.00'	59°19'21"	19.79'	N76°00'59"W
C22	165.91'	220.00'	43°12'28"	162.00'	N24°45'04"W
C23	46.98'	235.00'	11°27'12"	46.90'	S10°52'44"E
C24	42.76'	175.00'	14°00'00"	42.65'	S09°37'26"E
C25	31.65'	20.00'	90°40'17"	28.45'	S42°42'42"W
C26	175.08'	220.00'	45°35'51"	170.50'	N69°09'14"W

Ronnie L. Edwards

Sheet 11 of 12

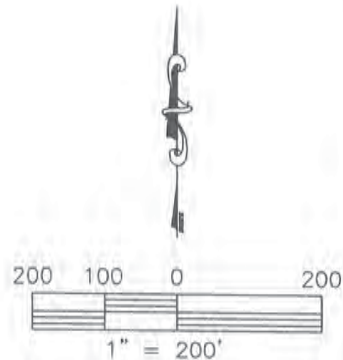
Ronnie L. Edwards - On Behalf Of King Surveyors
 Colorado Licensed Professional
 Land Surveyor #38480



NOTE: This exhibit drawing is not intended to be a monumented land survey. It's sole purpose is as a graphic representation to aid in the visualization of the written property description which it accompanies. The written property description supersedes the exhibit drawing.

NOTICE: According to Colorado law you must commence any legal action based upon any defect in this survey within three years after you first discover such defect. In no event may any action based upon any defect in this survey be commenced more than ten years from the date of the certification shown hereon. (13-80-105 C.R.S. 2012)



KING SURVEYORS
 650 E. Garden Drive | Windsor, Colorado 80550
 phone: (970) 686-5011 | fax: (970) 686-5821
 email: contact@KingSurveyors.com

PROJECT NO: 20170417
DATE: 08-30-2017
CLIENT: GENESIS DEVELOPMENT MANAGEMENT
DWG: 20170417DIST2
DRAWN: TJJ **CHECKED:** RLE

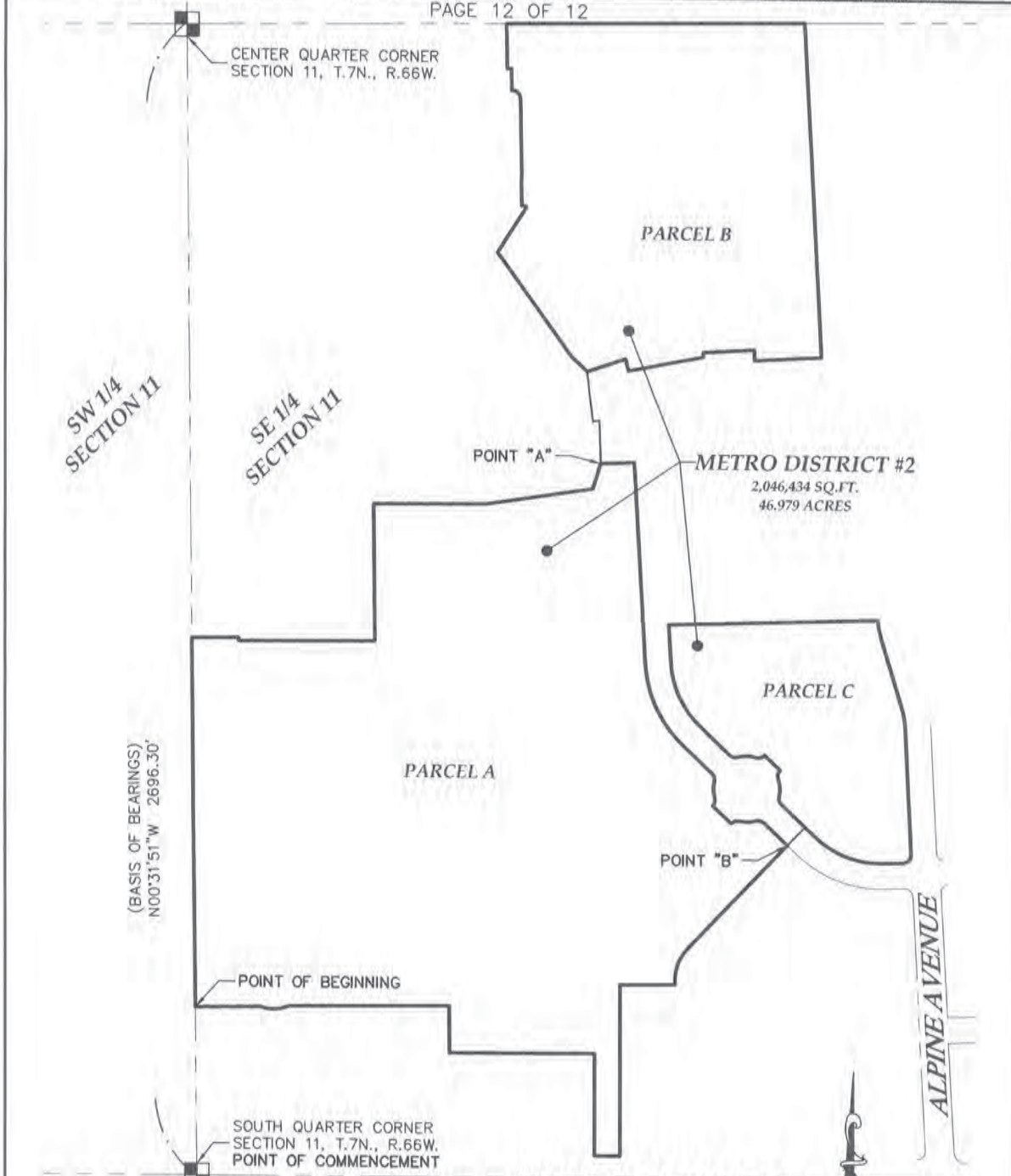

Ronnie L. Edwards
 COLORADO LICENSED PROFESSIONAL LAND SURVEYOR
 RONNIE L. EDWARDS
 38480
 8-30-17
 12/1/17

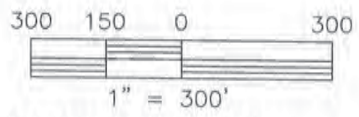

Ronnie L. Edwards -
 On Behalf Of King Surveyors Colorado
 Licensed Professional Land Surveyor #38480

NOTE: This exhibit drawing is not intended to be a monumented land survey. It's sole purpose is as a graphic representation to aid in the visualization of the written property description which it accompanies. The written property description supersedes the exhibit drawing.

NOTICE: According to Colorado law you must commence any legal action based upon any defect in this survey within three years after you first discover such defect. In no event may any action based upon any defect in this survey be commenced more than ten years from the date of the certification shown hereon. (13-80-105 C.R.S. 2012)



KING SURVEYORS
 650 E. Garden Drive | Windsor, Colorado 80550
 phone: (970) 686-5011 | fax: (970) 686-5821
 email: contact@KingSurveyors.com

PROJECT NO: 20170417
DATE: 08-30-2017
CLIENT: GENESIS DEVELOPMENT MANAGEMENT
DWG: 20170417DIST2
DRAWN: TJJ **CHECKED:** RLE

EXHIBIT A

PROPERTY DESCRIPTION

Conestoga Metro District #3

A parcel of land being a portion of Tract A, Tract 4 and Tract B of the First Replat of Conestoga Subdivision First Filing as recorded March 12, 2008 as Reception No. 3541114 of the Records of Weld County, situate in the Southeast Quarter (SE1/4) of Section Eleven (11), Township Seven North (T.7N.), Range Sixty-six West (R.66W.), Sixth Principal Meridian (6th P.M.), Town of Ault, County of Weld, State of Colorado and being more particularly described as follows:

COMMENCING at the South Quarter corner of said Section 11 and assuming the West line of said SE1/4 as bearing North 00°31'51" West being a Grid bearing of the Colorado State Plane Coordinate System, North Zone, North American Datum 1983/2011, a distance of 2696.30 feet with all other bearings contained herein relative thereto;

THENCE North 00°31'51" West along said West line a distance of 1260.42 feet to the **POINT OF BEGINNING**;

THENCE North 00°31'51" West along said West line a distance of 1435.88 feet to the North line of said SE1/4;

THENCE North 89°08'51" West along said North line a distance of 751.13 feet;

THENCE South 00°51'09" East a distance of 105.00 feet;

THENCE North 89°08'51" East a distance of 9.97 feet;

THENCE South 00°51'09" East a distance of 50.00 feet to the beginning point of a curve, non-tangent to this course;

THENCE along the arc of a curve concave to the Southwest a distance of 31.42 feet, said curve has a Radius of 20.00 feet, a Delta of 90°00'00" and is subtended by a Chord that bears South 45°51'09" East a distance of 28.28 feet to a Point of Tangency (PT);

THENCE South 00°51'09" East a distance of 164.41 feet to the beginning point of a curve, non-tangent to this course;

THENCE along the arc of a curve concave to the Northeast a distance of 14.55 feet, said curve has a Radius of 280.00 feet, a Delta of 02°58'41" and is subtended by a Chord that bears South 02°20'30" East a distance of 14.55 feet to a Point of Reverse Curvature (PRC);

THENCE along the arc of a curve concave to the Northwest a distance of 8.03 feet, said curve has a Radius of 20.00 feet, a Delta of 23°00'50" and is subtended by a Chord that bears South 07°40'35" West a distance of 7.98 feet to the end point of said curve;

THENCE South 00°51'09" East along a line non-tangent to the aforesaid course a distance of 63.15 feet to the beginning point of a curve non-tangent to this course;

THENCE along the arc of a curve concave to the Southwest a distance of 12.11 feet, said curve has a Radius of 20.00 feet, a Delta of 34°41'34" and is subtended by a Chord that bears South 73°30'22" East a distance of 11.93 feet to the end point of said curve;

THENCE South 32°21'20" West along a line non-tangent to the aforesaid course a distance of 127.22 feet;

THENCE South 35°46'48" East a distance of 297.00 feet;

THENCE South 46°58'44" East a distance of 51.50 feet to the Easterly line of said Tract A;

The following Four (4) courses are along the Easterly lines of said Tract A:

THENCE South 06°15'38" East a distance of 66.73 feet;

THENCE South 07°51'51" East a distance of 50.00 feet;

THENCE North 84°29'35" East a distance of 14.82 feet;

THENCE South 01°50'28" East a distance of 100.14 feet;



THENCE South 17°31'06" West a distance of 63.07 feet;
THENCE South 81°13'36" West a distance of 254.07 feet;
THENCE South 89°27'53" West a distance of 263.00 feet;
THENCE South 00°32'08" East a distance of 322.73 feet;
THENCE South 89°27'52" West a distance of 320.00 feet;
THENCE North 00°32'07" West a distance of 7.67 feet;
THENCE South 89°08'57" West a distance of 109.86 feet to the West line of the SE1/4 of said
Section 11 and to the **POINT OF BEGINNING**.

Said described parcel of land contains 1,068,592 Square Feet or 24.532 Acres, more or less (±) and
is subject to any rights-of-way or other easements of record or as now existing on said described
parcel of land.

SURVEYORS STATEMENT

I, Ronnie L. Edwards, a Colorado Licensed Professional Land Surveyor do hereby state that this
Parcel Description was prepared under my personal supervision and checking, and that it is true
and correct to the best of my knowledge and belief.

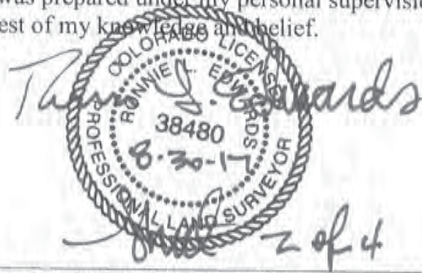

Ronnie L. Edwards - on behalf of King Surveyors
Colorado Licensed Professional
Land Surveyor #38480

KING SURVEYORS
650 East Garden Drive
Windsor, Colorado 80550
(970) 686-5011

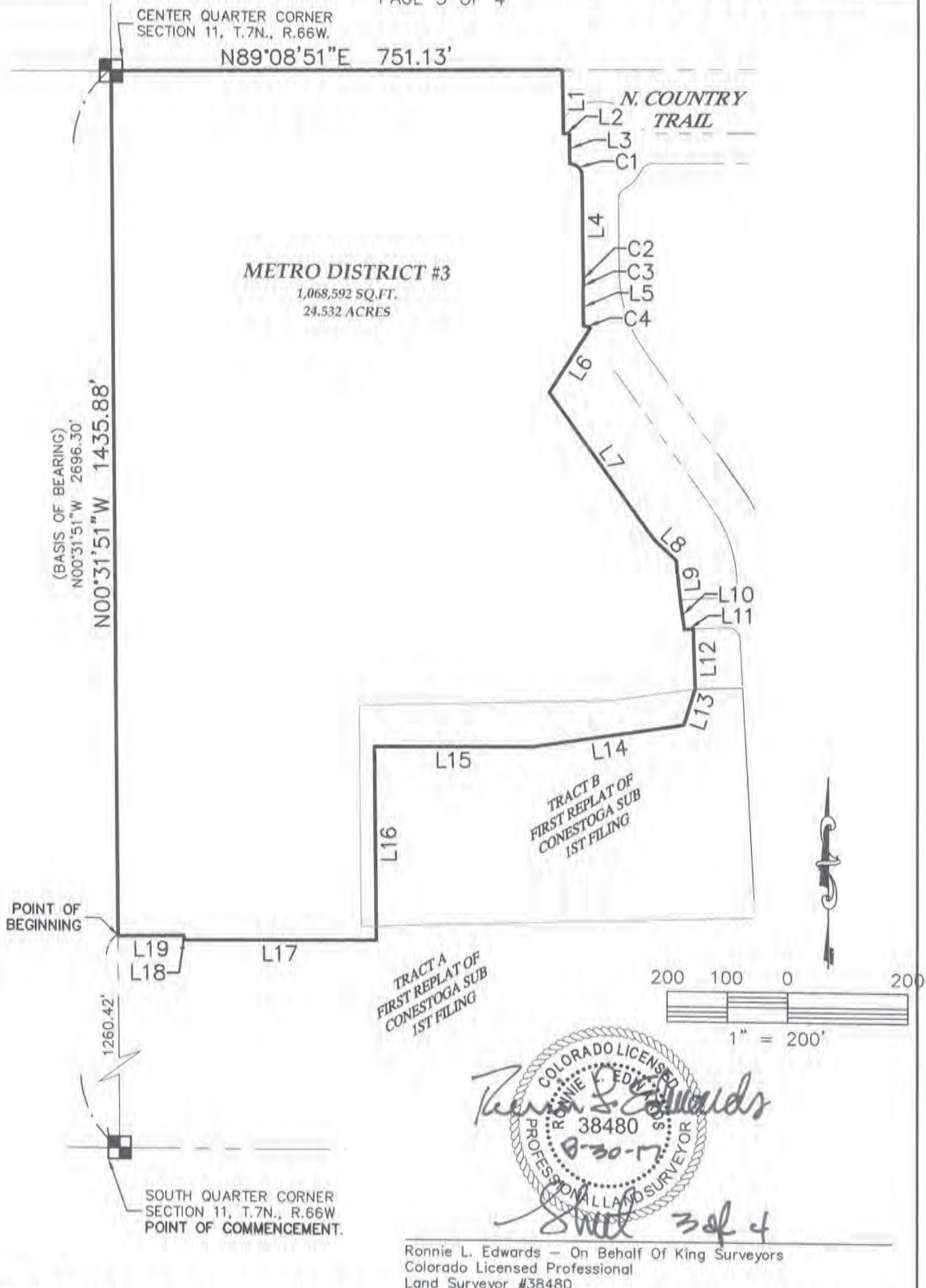

TRACT A
FIRST REPLAT OF
CONESTOGA SUB
1ST FILING

TRACT B
FIRST REPLAT OF
CONESTOGA SUB
1ST FILING

Ronnie L. Edwards
 38480
 8-30-17
 PROFESSIONAL LAND SURVEYOR

Ronnie L. Edwards - On Behalf Of King Surveyors
Colorado Licensed Professional
Land Surveyor #38480

NOTE: This exhibit drawing is not intended to be a monumented land survey. It's sole purpose is as a graphic representation to aid in the visualization of the written property description which it accompanies. The written property description supersedes the exhibit drawing.

NOTICE: According to Colorado law you must commence any legal action based upon any defect in this survey within three years after you first discover such defect. In no event may any action based upon any defect in this survey be commenced more than ten years from the date of the certification shown hereon. (13-80-105 C.R.S. 2012)



KING SURVEYORS

650 E. Garden Drive | Windsor, Colorado 80550
phone: (970) 686-5011 | fax: (970) 686-5821
email: contact@KingSurveyors.com

PROJECT NO: 20170417

DATE: 08-30-2017

CLIENT: GENESIS DEVELOPMENT MANAGEMENT

DWG: 20170417DIST3

DRAWN: TJJ CHECKED: RLE

LINE TABLE		
LINE	BEARING	LENGTH
L1	S00°51'09"E	105.00'
L2	N89°08'51"E	9.97'
L3	S00°51'09"E	50.00'
L4	S00°51'09"E	164.41'
L5	S00°51'09"E	63.15'
L6	S32°21'20"W	127.22'
L7	S35°46'48"E	297.00'
L8	S46°58'44"E	51.50'
L9	S06°15'38"E	66.73'
L10	S07°51'51"E	50.00'
L11	N84°29'35"E	14.82'
L12	S01°50'28"E	100.14'
L13	S17°31'06"W	63.07'
L14	S81°13'36"W	254.07'
L15	S89°27'53"W	263.00'
L16	S00°32'08"E	322.73'
L17	S89°27'52"W	320.00'
L18	N00°32'07"W	7.67'
L19	S89°08'57"W	109.86'

CURVE TABLE					
CURVE	LENGTH	RADIUS	DELTA	CHORD	CH BEARING
C1	31.42'	20.00'	90°00'00"	28.28'	S45°51'09"E
C2	14.55'	280.00'	2°58'41"	14.55'	S02°20'30"E
C3	8.03'	20.00'	23°00'50"	7.98'	S07°40'35"W
C4	12.11'	20.00'	34°41'34"	11.93'	S73°30'22"E

NOTE: This exhibit drawing is not intended to be a monumented land survey. It's sole purpose is as a graphic representation to aid in the visualization of the written property description which it accompanies. The written property description supersedes the exhibit drawing.

NOTICE: According to Colorado law you must commence any legal action based upon any defect in this survey within three years after you first discover such defect. In no event may any action based upon any defect in this survey be commenced more than ten years from the date of the certification shown hereon. (13-80-105 C.R.S. 2012)

Ronnie L. Edwards

Shel 4 of 4

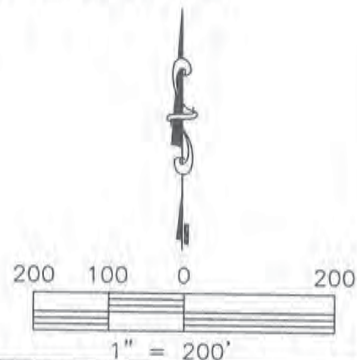
Ronnie L. Edwards – On Behalf Of King Surveyors
 Colorado Licensed Professional
 Land Surveyor #38480



KING SURVEYORS

650 E. Garden Drive | Windsor, Colorado 80550
 phone: (970) 686-5011 | fax: (970) 686-5821
 email: contact@KingSurveyors.com

PROJECT NO: 20170417
DATE: 08-30-2017
CLIENT: GENESIS DEVELOPMENT MANAGEMENT
DWG: 20170417DIST3
DRAWN: TJJ **CHECKED:** RLE

EXHIBIT A

PROPERTY DESCRIPTION

Conestoga Metro District #4

A parcel of land being a portion of Tract A of the First Replat of Conestoga Subdivision First Filing as recorded March 12, 2008 as Reception No. 3541114 of the Records of Weld County, situate in the Southeast Quarter (SE1/4) of Section Eleven (11), Township Seven North (T.7N.), Range Sixty-six West (R.66W.), Sixth Principal Meridian (6th P.M.), Town of Ault, County of Weld, State of Colorado and being more particularly described as follows:

COMMENCING at the South Quarter corner of said Section 11 and assuming the West line of said SE1/4 as bearing North 00°31'51" West being a Grid bearing of the Colorado State Plane Coordinate System, North Zone, North American Datum 1983/2011, a distance of 2696.30 feet with all other bearings contained herein relative thereto;

THENCE North 00°31'51" West along said West line a distance of 39.61 feet to the **POINT OF BEGINNING**;

THENCE North 00°31'51" West along said West line a distance of 355.80 feet;

THENCE North 89°08'57" East a distance of 155.05 feet to the beginning point of a curve, non-tangent to this course;

THENCE along the arc of a curve concave to the Northwest a distance of 60.30 feet, said curve has a Radius of 83.00 feet, a Delta of 41°37'45" and is subtended by a Chord that bears North 89°45'09" East a distance of 58.99 feet to a Point of Reverse Curvature;

THENCE along the arc of a curve concave to the Southeast a distance of 15.41 feet, said curve has a Radius of 43.00 feet, a Delta of 20°31'47" and is subtended by a Chord that bears North 79°12'10" East a distance of 15.33 feet to a Point of Tangency;

THENCE North 89°28'03" East a distance of 367.23 feet to the Northerly prolongation of the Westerly line of that parcel of land described in that Warranty Deed as recorded June 26, 1991 as Reception No. 2254460 of the Records of Weld County;

The following course is along said Northerly prolongation and along the Westerly line of that parcel of land described in that Warranty Deed as recorded June 26, 1991 as Reception No. 2254460 of the Records of Weld County:

THENCE South 00°12'15" East a distance of 364.53 feet to the Southerly line of said Tract A;

THENCE South 89°59'29" West along said Southerly line a distance of 594.29 feet to the **POINT OF BEGINNING**.

Said described parcel of land contains 214,565 Square Feet or 4.926 Acres, more or less (±) and is subject to any rights-of-way or other easements of record or as now existing on said described parcel of land.

SURVEYORS STATEMENT

I, Ronnie L. Edwards, a Colorado Licensed Professional Land Surveyor do hereby state that this Parcel Description was prepared under my personal supervision and checking, and that it is true and correct to the best of my knowledge and belief.

Ronnie L. Edwards - on behalf of King Surveyors
Colorado Licensed Professional
Land Surveyor #38480

KING SURVEYORS
650 East Garden Drive
Windsor, Colorado 80550
(970) 686-5011

EXHIBIT A

A PORTION OF TRACT A OF THE FIRST REPLAT OF CONESTOGA SUBDIVISION FIRST FILING SEQ OF SECTION 11, T.7N., R.66W.

PAGE 2 OF 2

CENTER QUARTER CORNER
SECTION 11, T.7N., R.66W.

CURVE TABLE					
CURVE	LENGTH	RADIUS	DELTA	CHORD	CH BEARING
C1	60.30'	83.00'	41°37'45"	58.99'	N89°45'09"E
C2	15.41'	43.00'	20°31'47"	15.33'	N79°12'10"E

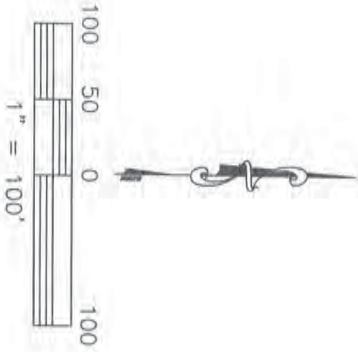

Ronnie L. Edwards - On Behalf Of King Surveyors
Colorado Licensed Professional
Land Surveyor #38480

NOTE: This exhibit drawing is not intended to be a monumented land survey. It's sole purpose is as a graphic representation to aid in the visualization of the written property description which it accompanies. The written property description supersedes the exhibit drawing.

NOTICE: According to Colorado law you must commence any legal action based upon any defect in this survey within three years after you first discover such defect. In no event may any action based upon any defect in this survey be commenced more than ten years from the date of the certification shown hereon. (13-80-105 C.R.S. 2012)



KING SURVEYORS
650 E. Garden Drive | Windsor, Colorado 80550
phone: (970) 686-5011 | fax: (970) 686-5821
email: contact@KingSurveyors.com

PROJECT NO: 201170417
DATE: 08-30-2017
CLIENT: GENESIS DEVELOPMENT MANAGEMENT
DWG: 201170417DIST4
DRAWN: TJJ CHECKED: RLE

EXHIBIT A

PROPERTY DESCRIPTION

Conestoga Metro District #5

A parcel of land being a portion of Tract A of the First Replat of Conestoga Subdivision First Filing as recorded March 12, 2008 as Reception No. 3541114 of the Records of Weld County, situate in the Southeast Quarter (SE1/4) of Section Eleven (11), Township Seven North (T.7N.), Range Sixty-six West (R.66W.), Sixth Principal Meridian (6th P.M.), Town of Ault, County of Weld, State of Colorado and being more particularly described as follows:

COMMENCING at the South Quarter corner of said Section 11 and assuming the South line of said SE1/4 as bearing North 89°52'51" East being a Grid bearing of the Colorado State Plane Coordinate System, North Zone, North American Datum 1983/2011, a distance of 2826.89 feet with all other bearings contained herein relative thereto;

THENCE North 89°52'51" East along said South line a distance of 993.84 feet;

THENCE North 00°07'09" West a distance of 53.45 feet to the **POINT OF BEGINNING**;

THENCE North 00°00'44" West a distance of 402.26 feet;

THENCE North 89°22'12" East a distance of 129.66 feet to the beginning point of a curve, non-tangent to this course;

THENCE along the arc of a curve concave to the Southeast a distance of 90.60 feet, said curve has a Radius of 103.60 feet, a Delta of 50°06'25" and is subtended by a Chord that bears North 18°35'28" East a distance of 87.74 feet to a Point of Tangency (PT);

THENCE North 43°38'41" East a distance of 340.34 feet to the Northeasterly line of said Tract A;

The following Seven (7) courses are along the Northeasterly, Easterly, and Southerly lines of said Tract A:

THENCE South 46°21'18" East a distance of 33.68 feet to a Point of Curvature (PC);

THENCE along the arc of a curve concave to the Northeast a distance of 222.83 feet, said curve has a Radius of 280.00 feet, a Delta of 45°35'51" and is subtended by a Chord that bears South 69°09'14" East a distance of 217.00 feet to a PT;

THENCE North 88°02'51" East a distance of 46.79 feet to a PC;

THENCE along the arc of a curve concave to the Southwest a distance of 31.11 feet, said curve has a Radius of 20.00 feet, a Delta of 89°07'10" and is subtended by a Chord that bears South 47°23'34" East a distance of 28.07 feet to a PT;

THENCE South 02°49'59" East a distance of 595.24 feet to a PC;

THENCE along the arc of a curve concave to the Northwest a distance of 32.41 feet, said curve has a Radius of 20.00 feet, a Delta of 92°51'11" and is subtended by a Chord that bears South 43°35'36" West a distance of 28.98 feet to a PT;

THENCE North 89°58'48" West a distance of 696.47 feet to the **POINT OF BEGINNING**.

Said described parcel of land contains 411,073 Square Feet or 9.437 Acres, more or less (±) and is subject to any rights-of-way or other easements of record or as now existing on said described parcel of land.

SURVEYORS STATEMENT

I, Ronnie L. Edwards, a Colorado Licensed Professional Land Surveyor do hereby state that this Parcel Description was prepared under my personal supervision and checking, and that it is true and correct to the best of my knowledge and belief.

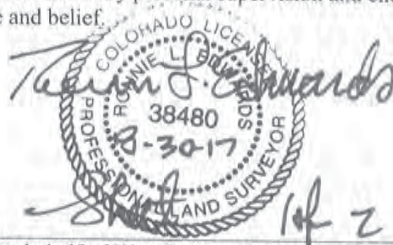

Ronnie L. Edwards - on behalf of King Surveyors
Colorado Licensed Professional
Land Surveyor #38480

KING SURVEYORS
650 East Garden Drive
Windsor, Colorado 80550
(970) 686-5011

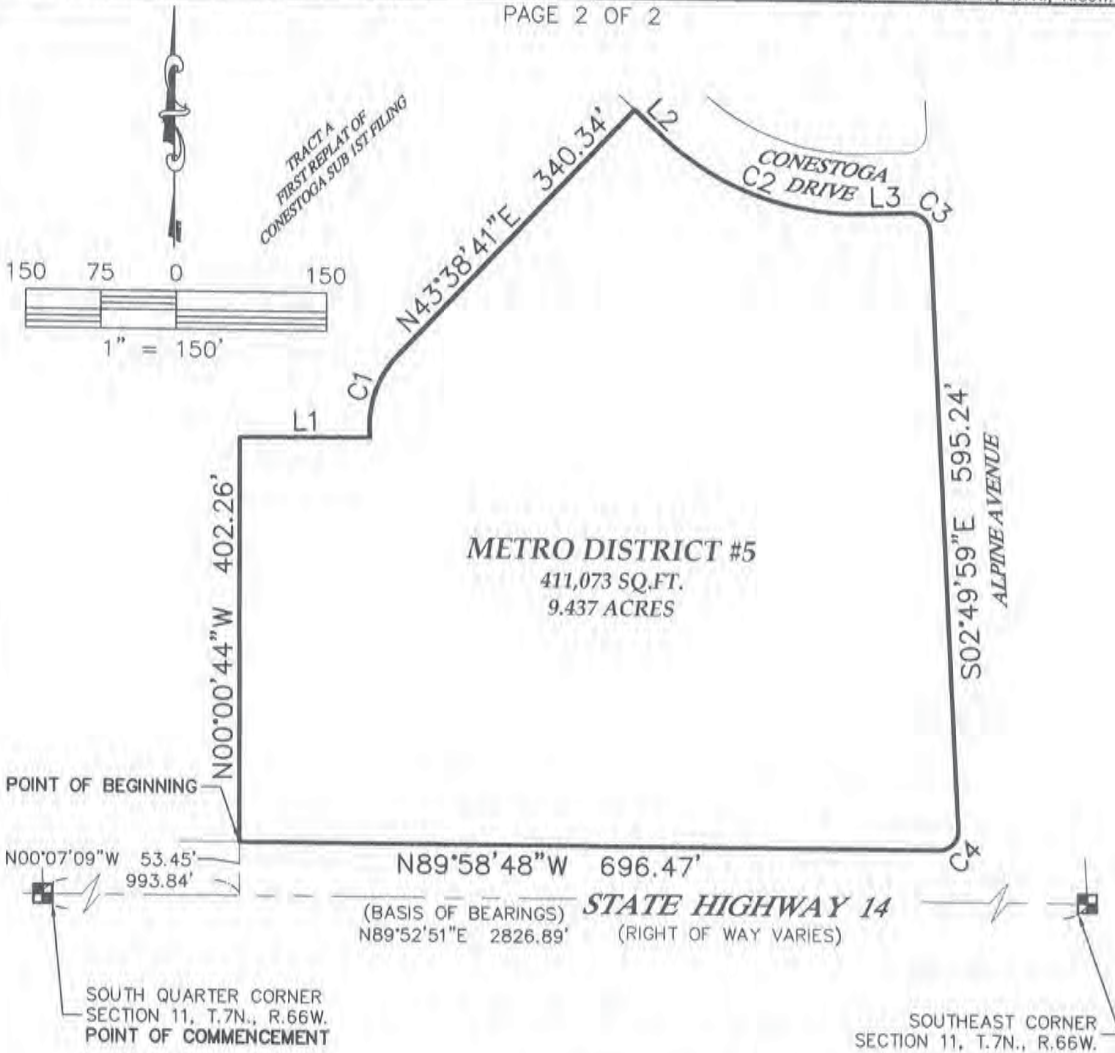

(BASIS OF BEARINGS) **STATE HIGHWAY 14**
 N89°52'51"E 2826.89' (RIGHT OF WAY VARIES)

CURVE	LENGTH	RADIUS	DELTA	CHORD	CH BEARING
C1	90.60'	103.60'	50°06'25"	87.74'	N18°35'28"E
C2	222.83'	280.00'	45°35'51"	217.00'	S69°09'14"E
C3	31.11'	20.00'	89°07'10"	28.07'	S47°23'34"E
C4	32.41'	20.00'	92°51'11"	28.98'	S43°35'36"W

LINE	BEARING	LENGTH
L1	N89°22'12"E	129.66'
L2	S46°21'18"E	33.68'
L3	N88°02'51"E	46.79'

Ronnie L. Edwards
 COLORADO LICENSED PROFESSIONAL LAND SURVEYOR
 38480
 8-30-17
 2/2

Ronnie L. Edwards - On Behalf Of King Surveyors
 Colorado Licensed Professional
 Land Surveyor #38480

NOTE: This exhibit drawing is not intended to be a monumented land survey. It's sole purpose is as a graphic representation to aid in the visualization of the written property description which it accompanies. The written property description supersedes the exhibit drawing.

NOTICE: According to Colorado law you must commence any legal action based upon any defect in this survey within three years after you first discover such defect. In no event may any action based upon any defect in this survey be commenced more than ten years from the date of the certification shown hereon. (13-80-105 C.R.S. 2012)



KING SURVEYORS
 650 E. Garden Drive | Windsor, Colorado 80550
 phone: (970) 686-5011 | fax: (970) 686-5821
 email: contact@KingSurveyors.com

PROJECT NO: 20170417
DATE: 08-30-2017
CLIENT: GENESIS DEVELOPMENT MANAGEMENT
DWG: 20170417DIST5
DRAWN: TJJ **CHECKED:** RLE